

8. CHASSIS / CHASSIS

604 110 951A	ASSY FRT CHASSIS W/BRGS NEO	<i>ENS. CHASSIS AVT /ROTULE NEO</i>
604 141 283C	ASSY FRONT PROTECTION N65 NEO	<i>ENSEMBLE BOUCLIER AVANT N65 NEO</i>
604 141 293C	ASSY REAR PROTECTION N65 NEO	<i>ENSEMBLE BOUCLIER ARRIERE N65 NEO</i>
604 141 452B	ASSY COMPLETE WALKWAY	<i>ENSEMBLE PLATELAGE COMPLET</i>
604 141 363A	ASSY RIGHT CAB ACCESS NEO	<i>PLATEFORME DROITE CABINE NEO</i>
604 141 353A	ASSY LEFT CAB ACCESS NEO	<i>PLATEFORME GAUCHE CABINE NEO</i>
604 141 343A	RIGHT HANDRAIL FRONT N65NEO	<i>GARDE-CORPS AVANT GAUCHE N65 NEO</i>
604 141 333A	LEFT HANDRAIL FRONT N65NEO	<i>GARDE-CORPS AVANT DROIT N65 NEO</i>
604 141 463A	ASSY RIGHT LIFT WALKWAY	<i>ENS. PLATELAGE CHASSIS LIFT DROIT</i>
604 141 473A	ASSY LEFT LIFT WALKWAY	<i>ENS. PLATELAGE CHASSIS LIFT GAUCHE</i>
604 140 423B	ASSY RIGHT FRONT WALKWAY	<i>ENS. AV DROIT PATELAGE</i>
604 140 433B	ASSY LEFT FRONT WALKWAY	<i>ENS. AV GAUCHE PATELAGE</i>
604 140 463C	ASSY. RIGHT ENGINE WALKWAY	<i>ENS. PLATELAGE MOTEUR DROIT</i>
604 140 473C	ASSY. LEFT ENGINE WALKWAY	<i>ENS. PLATELAGE MOTEUR GAUCHE</i>
604 160 104B	ASSY. REAR LADDER	<i>ENS. ECHELLE PARECHOC AR</i>
604 791 093A	ASSY. DGPS/GPS ANTENNA SUPPORT	<i>ENS. SUPPORT ANTENNE DGPS/GPS</i>
604 001 231A	ASSY. N65NEO ON TRACKS	<i>ENS. N65NEO AVEC CHENILLES</i>
604 160 094B	REAR BUMPER EXTRACT LADDER	<i>RALLONGE ECH. PARECHOC AR</i>
604 190 403E	OPTION LEST	<i>OPTION LEST</i>

D

C

B

A

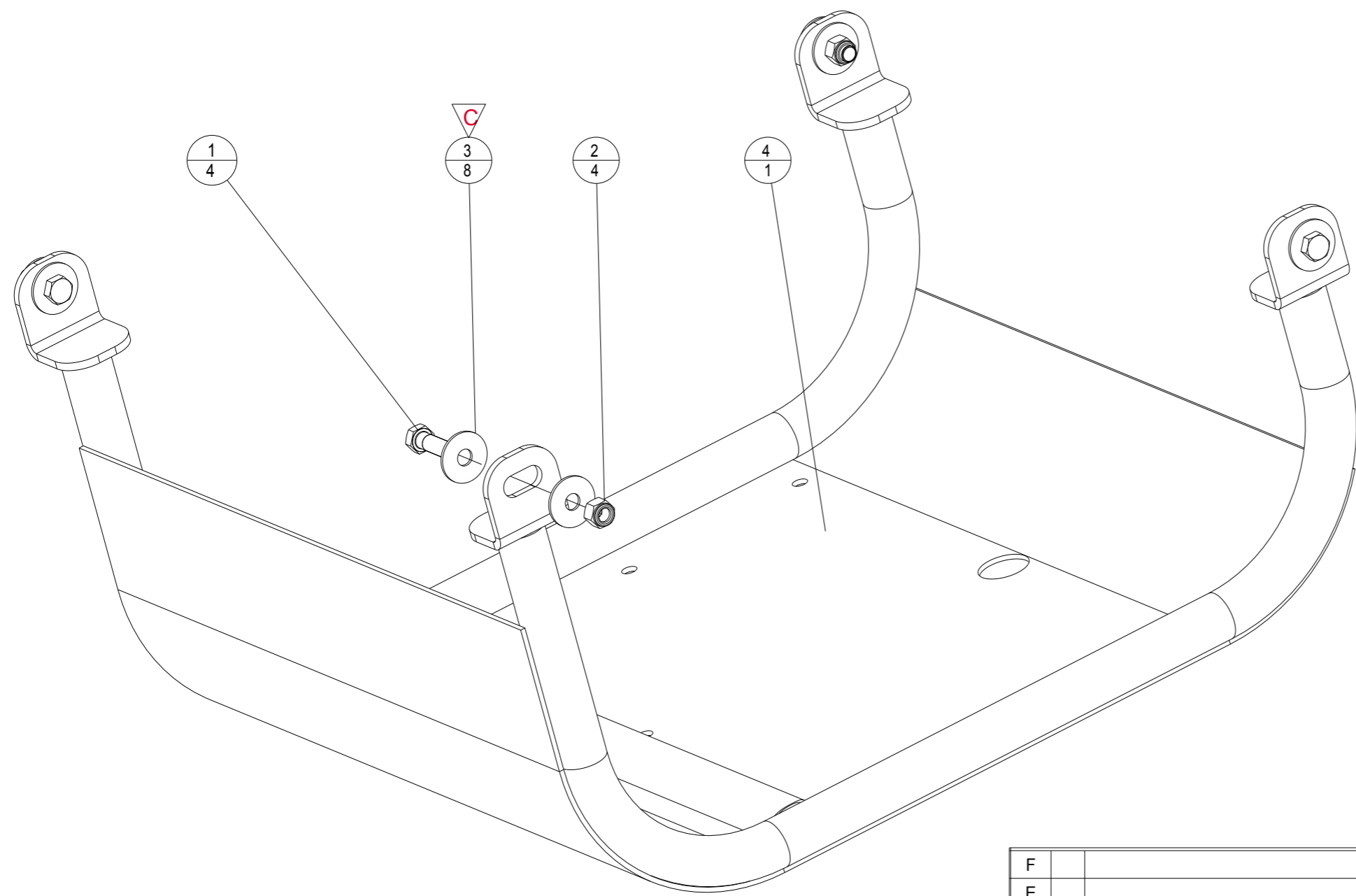

2

F							
E							
D							
C	T	ECO 207771	SOU M D.	04/04/17		BUTTIN P.	04/04/17
B	D	ECO 204210	VIAULES T.	26/08/14		BUTTIN P.	26/08/14
A		CREATION	SOU M D.	29/03/12		BUTTIN P.	29/03/12
REV	D/T	NATURE DE LA MODIFICATION TYPE OF MODIFICATION	DESSINE/VERIFIE DRAWN/VERIFIED	DATE	VISA	APPOUVE APPROVED	DATE VISA

1

MATIERE/MATERIAL:	COULEUR/COLOR:	MASSE/WEIGHT: 0,053 T
TRAITEMENT/TREATMENT:	VOLUME: m3	

TITRE/TITLE **LE PLAN ORIGINAL SIGNE EST AU PLANEX**

N65

ENSEMBLE BOUCLIER AV. / ASSY BUMPER

ETAT DE SURFACE/MACHINE FINISH: **SUIVANT INSTRUCTION: S902000324**

REP ITM	CODE SERCEL PART NUM.	DESIGNATION DESCRIPTION	REFERENCE / SPECIF. / LA PART NUMBER / SPECIF.	QTE QTY
1	211111411	VIS H M16-50 8.8 ZB. / BOLT HEX ZINC-PLATED	SERCEL	4
2	216411160	ECROU M16, B. PLAST CL8 Z.B / NUT LOCK	SERCEL	4
3	217341160	RONDELLE M16 LL,U.Z.B / PLAIN HEAVY DUTY WASHER	SERCEL	8
4	400253093	SOUDAGE BOUCLIER ARR / WELDING REAR SKID	SERCEL	1

CE PLAN EST LA PROPRIETE INALIENABLE DE **SERCEL** ETABLISSEMENT DE SAINT GAUDENS

NUMERO DE PLAN / DRAWING REFERENCE **604141283**

BP 69 - 31802 SAINT-GAUDENS CEDEX (FRANCE)
Tel:(33)(0)561899000 Fax:(33)(0)5 61899033

CODE OTAN : F2577

Echel: 0,200
Scale
CLQ:
REF
CL : 04
ART
Folio: 1/1

S 904 00 0233/00 Ce document est la propriété de SERCEL St-GAUDENS, toute reproduction et diffusion sont interdites sans son autorisation

D

C

B

A

D

C

B

A

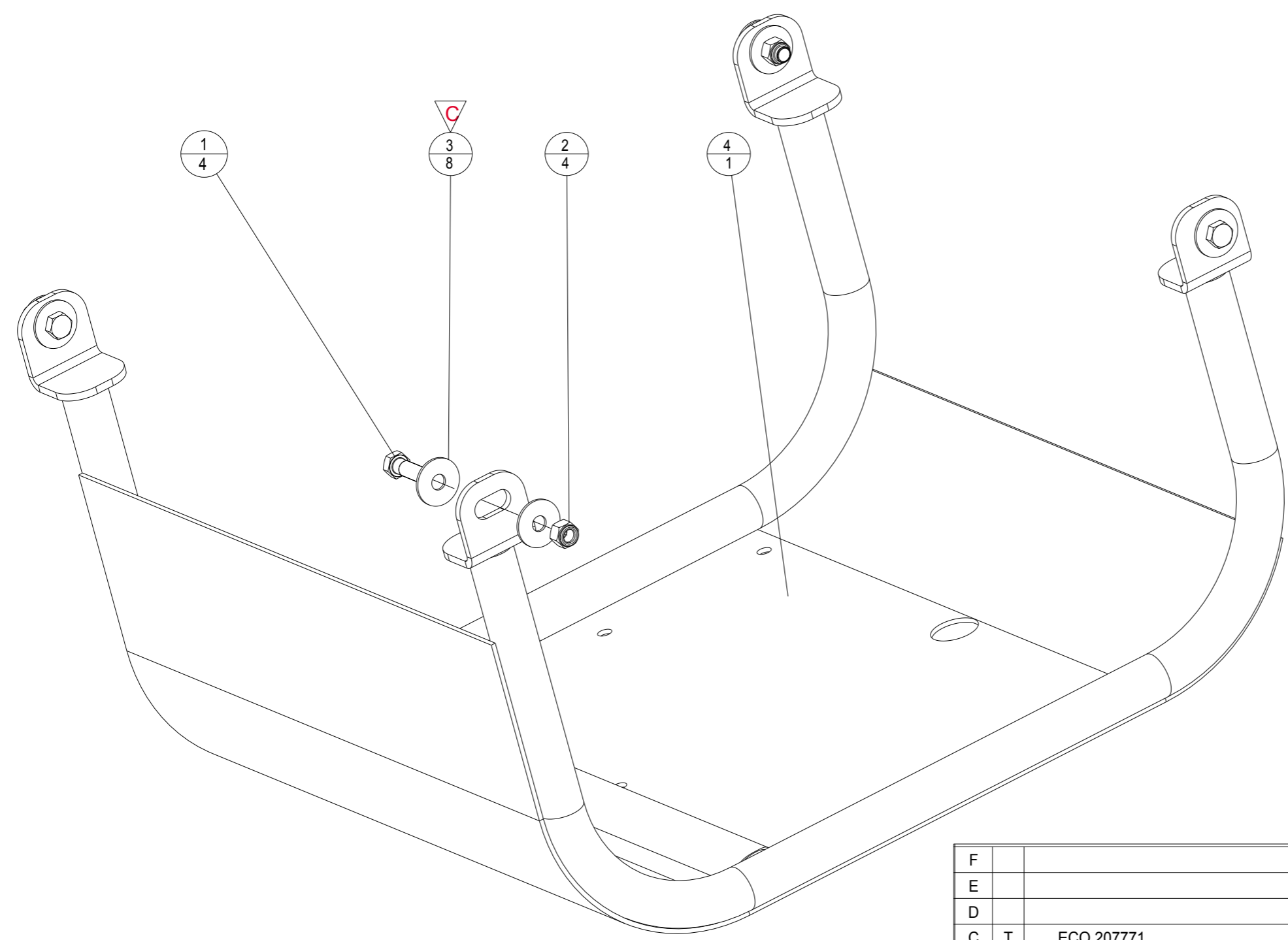

2

F							
E							
D							
C	T	ECO 207771	SOU M D.	04/04/17		BUTTIN P.	04/04/17
B	D	ECO 204210	VIAULES T.	26/08/14		BUTTIN P.	26/08/14
A		CREATION	SOU M D.	29/03/12		BUTTIN P.	29/03/12
REV	D/T	NATURE DE LA MODIFICATION TYPE OF MODIFICATION	DESSINE/VERIFIE DRAWN/VERIFIED	DATE	VISA	APPOUVE APPROVED	DATE VISA

1

MATIERE/MATERIAL:	COULEUR/COLOR:	MASSE/WEIGHT: 0,055 T
TRAITEMENT/TREATMENT:	VOLUME: m3	

TITRE/TITLE
N65
ENSEMBLE BOUCLIER AR. / ASSY BUMPER

LE PLAN ORIGINAL SIGNE EST AU PLANEX

ETAT DE SURFACE/MACHINE FINISH:
SUIVANT INSTRUCTION:
S902000324

REP ITM	CODE SERCEL PART NUM.	DESIGNATION DESCRIPTION	REFERENCE / SPECIF. / LA PART NUMBER / SPECIF.	QTE QTY
1	211111411	VIS H M16-50 8.8 ZB. / BOLT HEX ZINC-PLATED	SERCEL	4
2	216411160	ECROU M16, B. PLAST CL8 Z.B / NUT LOCK	SERCEL	4
3	217341160	RONDELLE M16 LL,U.Z.B / PLAIN HEAVY DUTY WASHER	SERCEL	8
4	400253123	SOUDAGE BOUCLIER ARR / WELDING REAR SKID	SERCEL	1

CE PLAN EST LA PROPRIETE INALIENABLE DE

SERCEL ETABLISSEMENT
DE SAINT GAUDENS

NUMERO DE PLAN / DRAWING REFERENCE
604141293

BP 69 - 31802 SAINT-GAUDENS CEDEX (FRANCE)
Tel:(33)0561899000 Fax:(33)05 61899033

CODE OTAN : F2577

Echel: 0,200
Scale
CLQ:
REF
CL : 04
ART
Folio: 1/1

S 904 00 0233/00 Ce document est la propriété de SERCEL St-GAUDENS, toute reproduction et diffusion sont interdites sans son autorisation

D

C

B

A

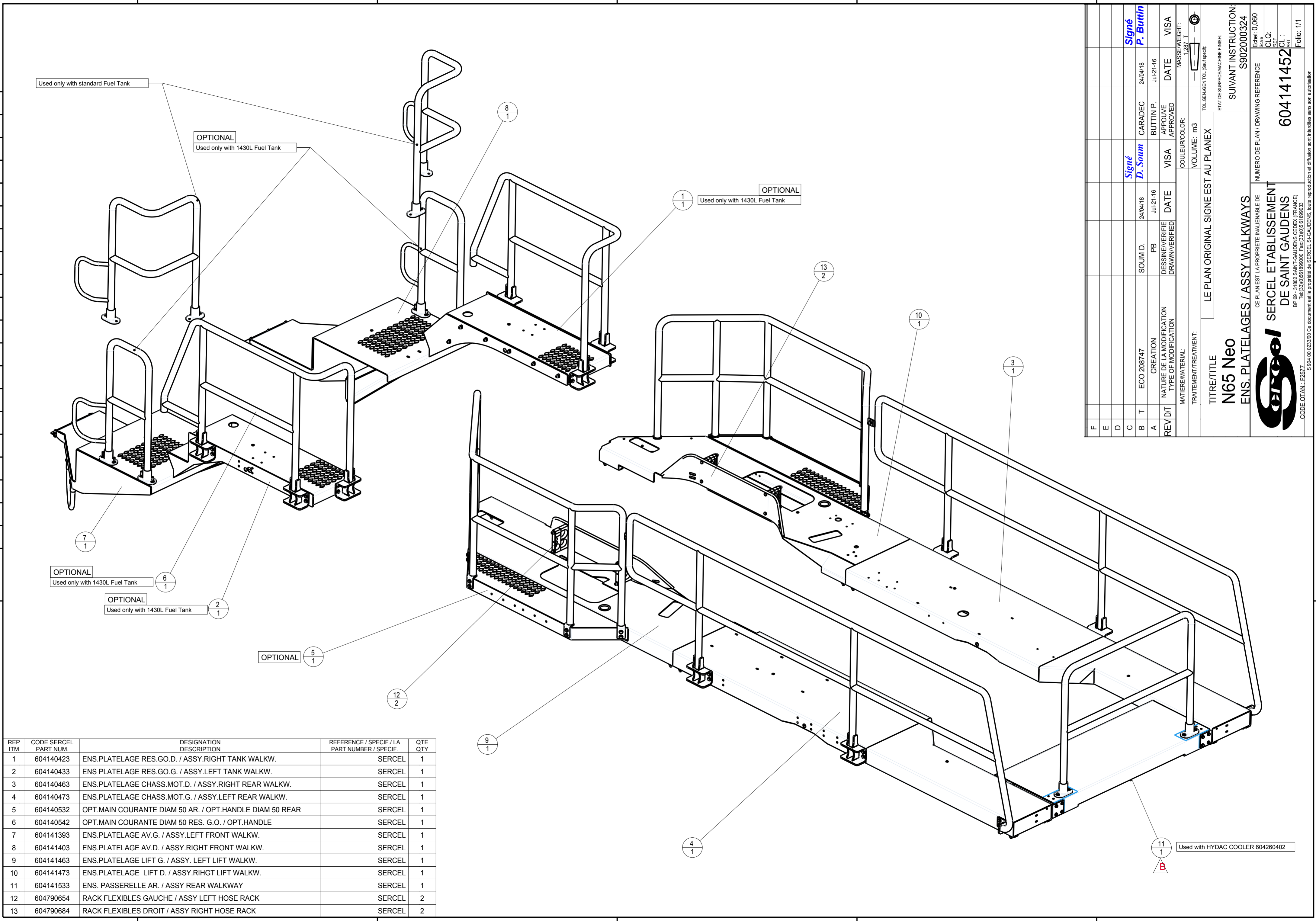

REP ITM	CODE SERCEL PART NUM.	DESIGNATION DESCRIPTION	REFERENCE / SPECIF / LA PART NUMBER / SPECIF.	QTE QTY
1	604140423	ENS.PLATELAGE RES.GO.D. / ASSY.RIGHT TANK WALKW.	SERCEL	1
2	604140433	ENS.PLATELAGE RES.GO.G. / ASSY.LEFT TANK WALKW.	SERCEL	1
3	604140463	ENS.PLATELAGE CHASS.MOT.D. / ASSY.RIGHT REAR WALKW.	SERCEL	1
4	604140473	ENS.PLATELAGE CHASS.MOT.G. / ASSY.LEFT REAR WALKW.	SERCEL	1
5	604140532	OPT.MAIN COURANTE DIAM 50 AR. / OPT.HANDLE DIAM 50 REAR	SERCEL	1
6	604140542	OPT.MAIN COURANTE DIAM 50 RES. G.O. / OPT.HANDLE	SERCEL	1
7	604141393	ENS.PLATELAGE AV.G. / ASSY.LEFT FRONT WALKW.	SERCEL	1
8	604141403	ENS.PLATELAGE AV.D. / ASSY.RIGHT FRONT WALKW.	SERCEL	1
9	604141463	ENS.PLATELAGE LIFT G. / ASSY. LEFT LIFT WALKW.	SERCEL	1
10	604141473	ENS.PLATELAGE LIFT D. / ASSY.RIHGT LIFT WALKW.	SERCEL	1
11	604141533	ENS. PASSERELLE AR. / ASSY REAR WALKWAY	SERCEL	1
12	604790654	RACK FLEXIBLES GAUCHE / ASSY LEFT HOSE RACK	SERCEL	2
13	604790684	RACK FLEXIBLES DROIT / ASSY RIGHT HOSE RACK	SERCEL	2

Signé P. Buttin		24/04/18		CARADEC	
Signé D. Soum		Jul-21-16		BUTTIN P.	
SOU D.		PB		DATE	
ECO 208747		DESSEINER/VERIFIE DRAWING/VERIFIED		DATE	
CREATION		DATE		VISA APPROUVE	
NATURE DE LA MODIFICATION TYPE OF MODIFICATION		DATE		VISA APPROUVE	
REV D/T		DATE		VISA APPROUVE	
MATERIE/MATERIAL:		COULEUR/COLOR:		MASSE/WEIGHT:	
TRAITEMENT/TREATMENT:		VOLUME: m3		1,287 T	
TITRE/TITLE		LE PLAN ORIGINAL SIGNE EST AU PLANEX		TOL.GEN.GEN.TOL (Sans approuv)	
N65 Neo		SUIVANT INSTRUCTION		S902000324	
ENS. PLATELAGES / ASSY WALKWAYS		NUMERO DE PLAN / DRAWING REFERENCE		S902000324	
SERCET ETABLISSEMENT DE SAINT GAUDENS		Echelle: 0,060		Scale: REF	
CODE OTAN: E2577		S 904 00 025300 Ce document est la propriété de SERCEL ST-GAUDENS. toute reproduction et diffusion sont interdites sans son autorisation		Folio: 1/1	

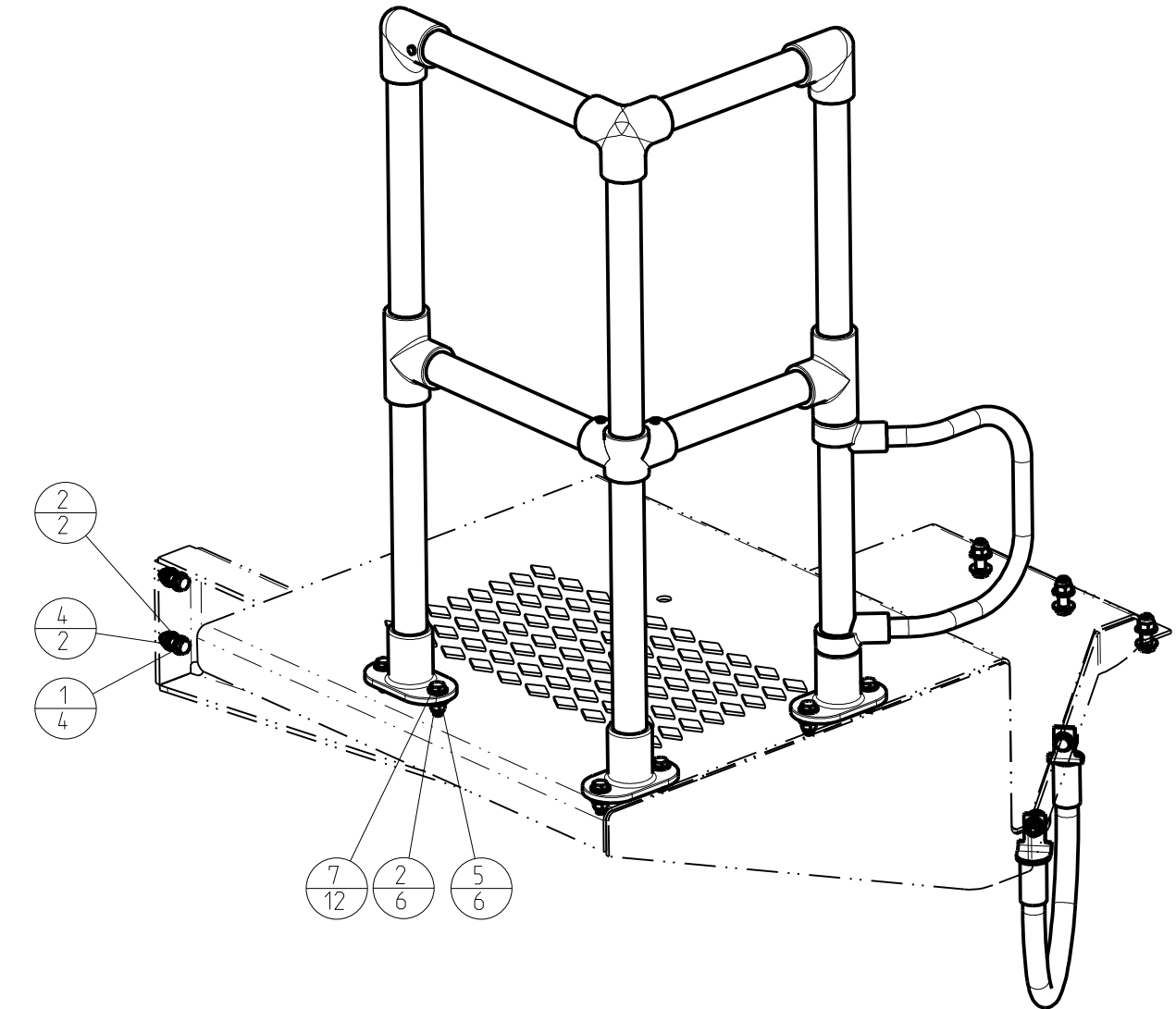
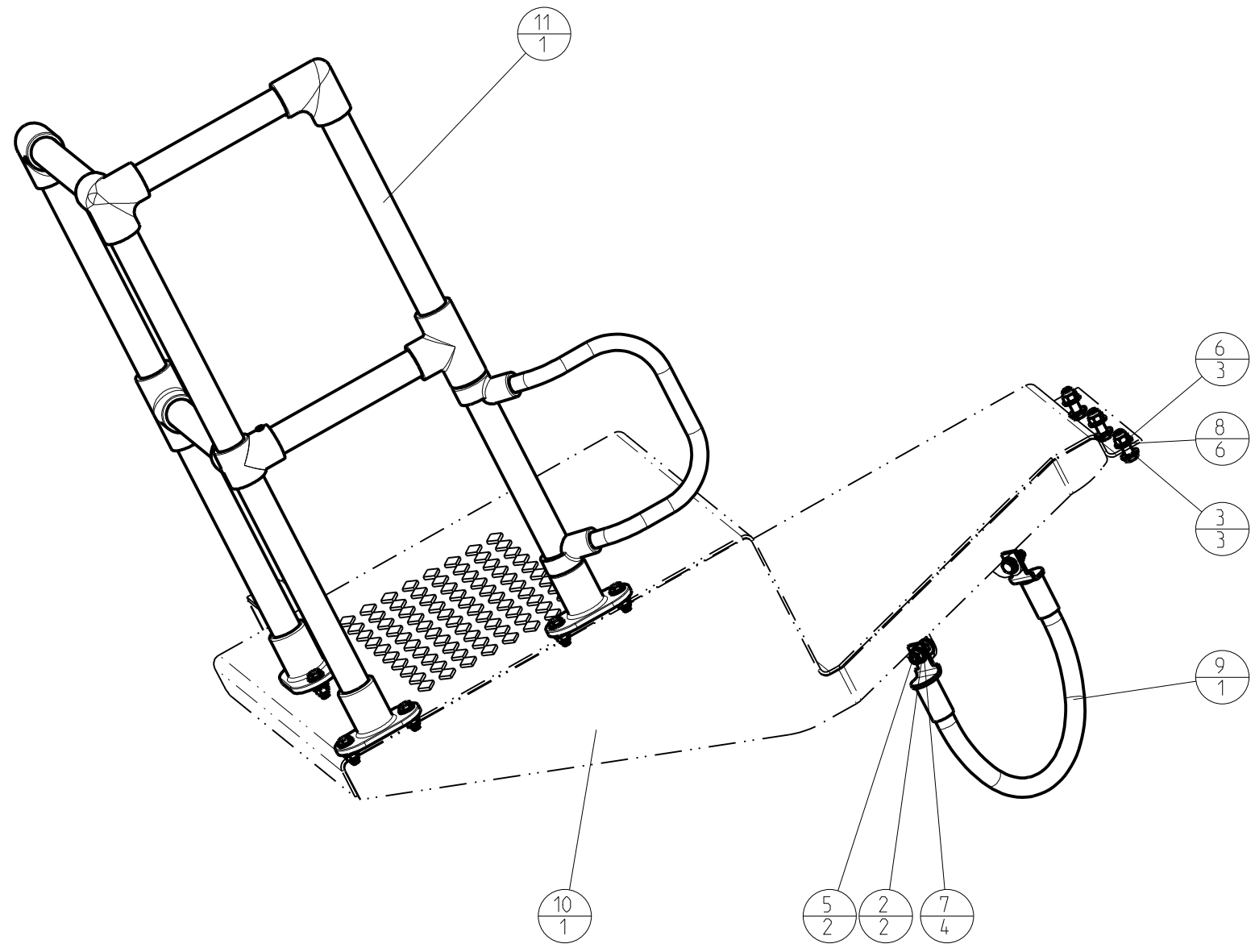

REP ITM	CODE SERCEL PART NUM.	DESIGNATION DESCRIPTION	REFERENCE / SPECIF / LA PART NUMBER / SPECIF.	QTE QTY
1	10006337	RONDELLE ANTI VIBR. M12 LG / VIBR. PROOF WASHER	SERCEL	4
2	211111369	VIS H M12-40 8.8 ZB. / BOLT HEX ZINC-PLATED	SERCEL	10
3	211111390	VIS H M14-45 8.8 ZB. / BOLT HEX ZINC-PLATED	SERCEL	3
4	216111120	ECROU H M12 8.8 BRUT / NUT H	SERCEL	2
5	216411120	ECROU M12, B. PLAST CL8 Z.B / NUT LOCK	SERCEL	8
6	216411140	ECROU M14, B. PLAST CL8 Z.B / NUT LOCK	SERCEL	3
7	217141120	RONDELLE M12,U,Z.B / PLAIN HEAVY DUTY WASHER	SERCEL	16
8	217141140	RONDELLE M14,U,Z.B / PLAIN HEAVY DUTY WASHER	SERCEL	6
9	400161353	MARCHE PIED / CABLE STEP	SERCEL	1
10	400264133	PLATELAGE AVANT DROIT / RIGHT FRONT WALKWAY	SERCEL	1
11	604141343	GARDE CORPS AV.DROIT / RIGHT FRONT GUARD RAIL	SERCEL	1

F									
E									
D									
C									
B									
A	CREATION	SOUM D.	10-Apr-14	BUTTIN P.	10-Apr-14				
REV D/T	NATURE DE LA MODIFICATION TYPE OF MODIFICATION	DESSINE/VERIFIE DRAWN/VERIFIED	DATE	VISA	APPROUVE APPROVED	DATE	VISA		
MATIERE/MATERIAL:				COULEUR/COLOR:		MASSE/WEIGHT: 0,134 T			
TRAITEMENT/TREATMENT:				VOLUME: m3		TOL.GEN./GEN.TOL.(Sauf specifi):			
TITRE/TITLE						LE PLAN ORIGINAL SIGNE EST AU PLANEX			
N65 Neo						ETAT DE SURFACE/MACHINE FINISH: SUIVANT INSTRUCTION: S902000324			
ENS.PLATELAGE AV.D. / ASSY.RIGHT FRONT WALKW.									
CE PLAN EST LA PROPRIETE INALIENABLE DE			NUMERO DE PLAN / DRAWING REFERENCE			Echel: 0,100 Scale			
SERCEL			SERCEL ETABLISSEMENT DE SAINT GAUDENS			604141363			
BP 69 - 31802 SAINT-GAUDENS CEDEX (FRANCE) Tel:(33)(0)561899000 Fax:(33)(0)5 61899033						CL : 04 ART			
CODE OTAN : F2577						Folio: 1/1			
S 904 00 0233/00 Ce document est la propriété de SERCEL St-GAUDENS, toute reproduction et diffusion sont interdites sans son autorisation									

D

C

B

DRW 604141363 Version AA

A

D

C

B

A

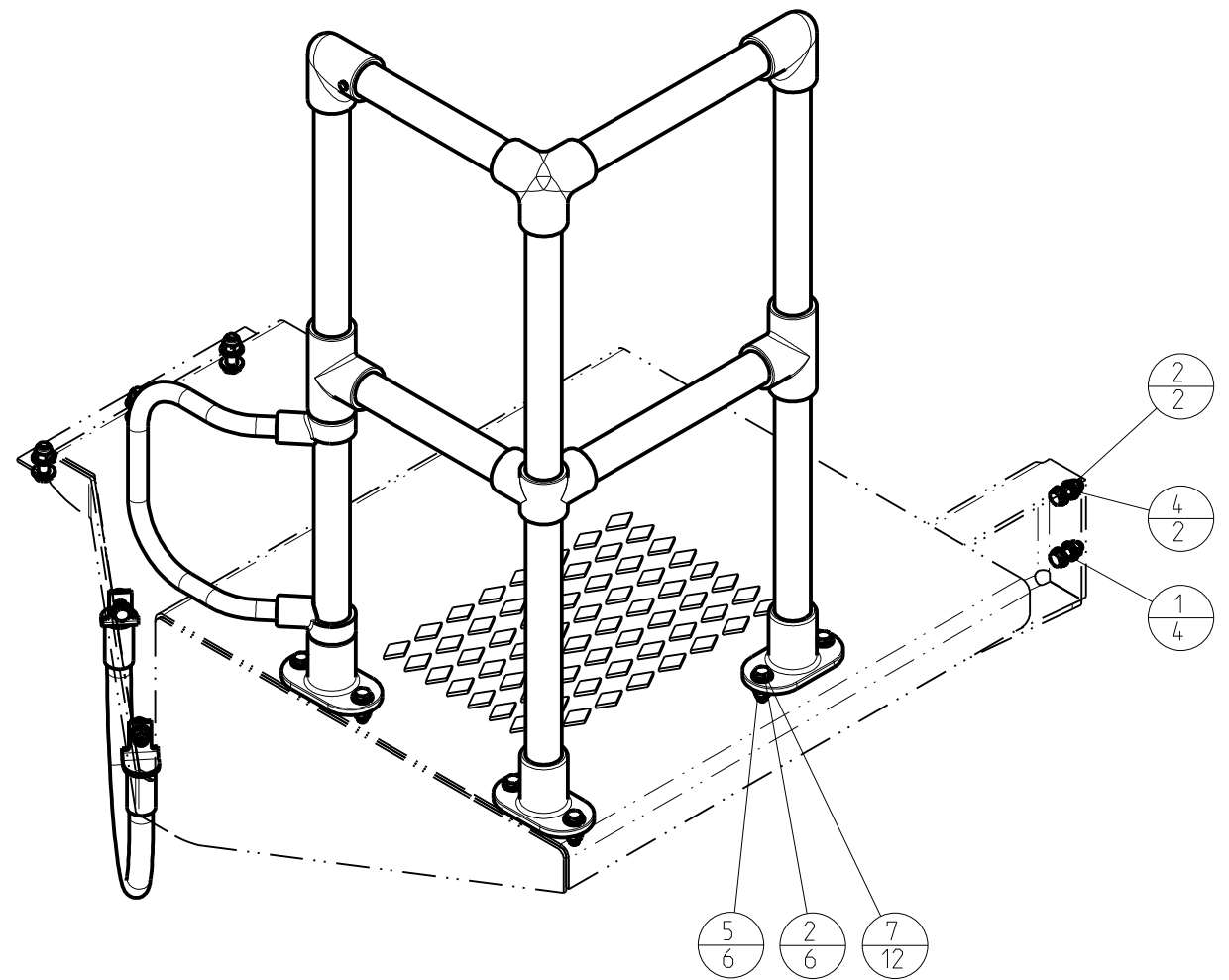
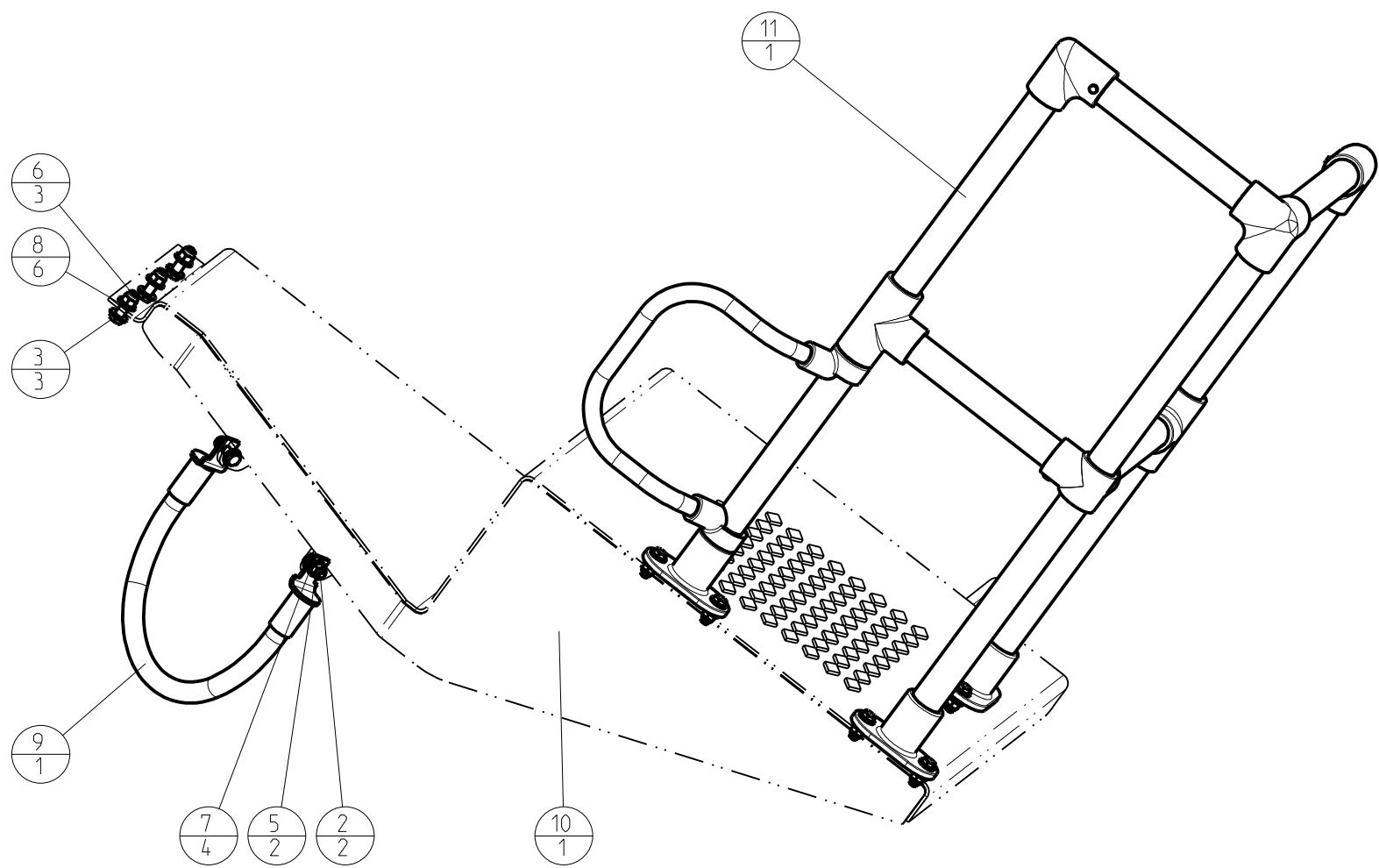

REP ITM	CODE SERCEL PART NUM.	DESIGNATION DESCRIPTION	REFERENCE / SPECIF. / LA PART NUMBER / SPECIF.	QTE QTY
1	10006337	RONDELLE ANTI VIBR. M12 LG / VIBR. PROOF WASHER	SERCEL	4
2	211111369	VIS H M12-40 8.8 ZB. / BOLT HEX ZINC-PLATED	SERCEL	10
3	211111390	VIS H M14-45 8.8 ZB. / BOLT HEX ZINC-PLATED	SERCEL	3
4	216111120	ECROU H M12 8.8 BRUT / NUT H	SERCEL	2
5	216411120	ECROU M12, B. PLAST CL8 Z.B / NUT LOCK	SERCEL	8
6	216411140	ECROU M14, B. PLAST CL8 Z.B / NUT LOCK	SERCEL	3
7	217141120	RONDELLE M12,U,Z.B / PLAIN HEAVY DUTY WASHER	SERCEL	16
8	217141140	RONDELLE M14,U,Z.B / PLAIN HEAVY DUTY WASHER	SERCEL	6
9	400161353	MARCHE PIED / CABLE STEP	SERCEL	1
10	400264083	PLATELAGE AVANT GAUCHE / LEFT FRONT WALKWAY	SERCEL	1
11	604141333	GARDE CORPS AV.GAUCHE / LEFT FRONT GUARD RAIL	SERCEL	1

F									
E									
D									
C									
B									
A	CREATION	SOUM D.	09-Apr-14	BUTTIN P.	09-Apr-14				
REV D/T	NATURE DE LA MODIFICATION TYPE OF MODIFICATION	DESSINE/VERIFIE DRAWN/VERIFIED	DATE	VISA	APPOUVE APPROVED	DATE	VISA		
MATIERE/MATERIAL:				COULEUR/COLOR:		MASSE/WEIGHT: 0,134 T			
TRAITEMENT/TREATMENT:				VOLUME: m3		TOL.GEN./GEN.TOL.(Sauf specifi):			
TITRE/TITLE						LE PLAN ORIGINAL SIGNE EST AU PLANEX			
N65 Neo						ETAT DE SURFACE/MACHINE FINISH: SUIVANT INSTRUCTION: S902000324			
ENS.PLATELAGE AV.G. / ASSY.LEFT FRONT WALKW.						NUMERO DE PLAN / DRAWING REFERENCE			
						604141353			
CE PLAN EST LA PROPRIETE INALIENABLE DE						Echelle: 0,100			
SERCEL ETABLISSEMENT DE SAINT GAUDENS						CL: 04			
BP 69 - 31802 SAINT-GAUDENS CEDEX (FRANCE) Tel:(33)(0)561899000 Fax:(33)(0)5 61899033						Folio: 1/1			
S 904 00 0233/00 Ce document est la propriété de SERCEL ST-GAUDENS, toute reproduction et diffusion sont interdites sans son autorisation									

D

C

B

A



DRW 604141353 Version AA

D C B A

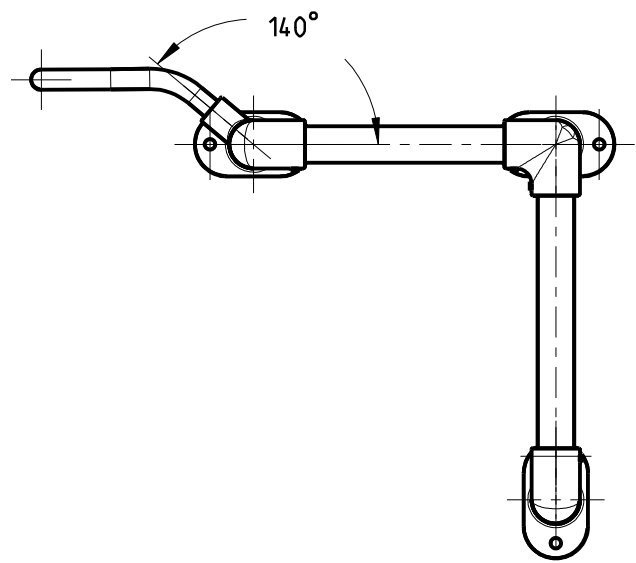
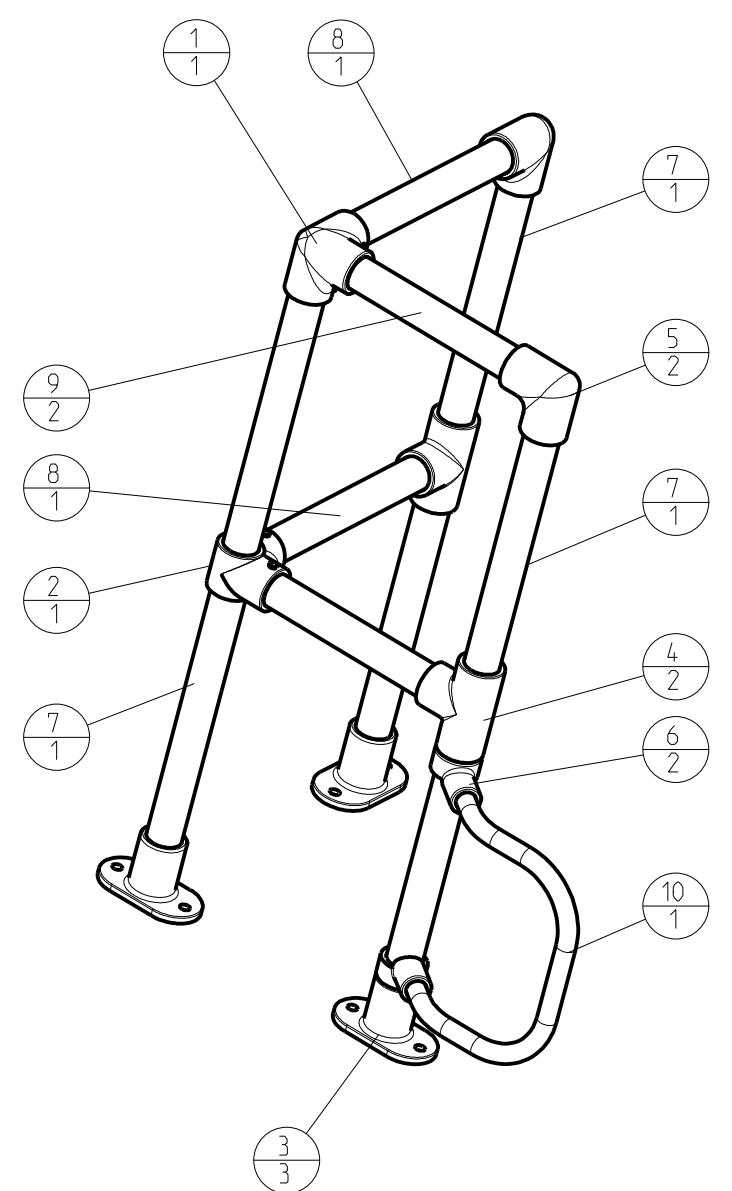
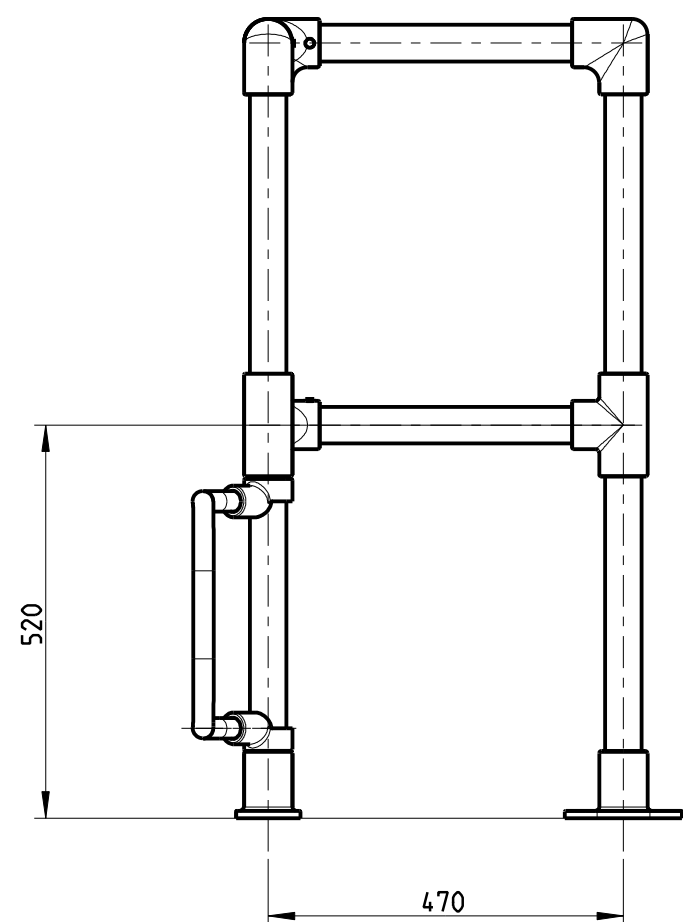
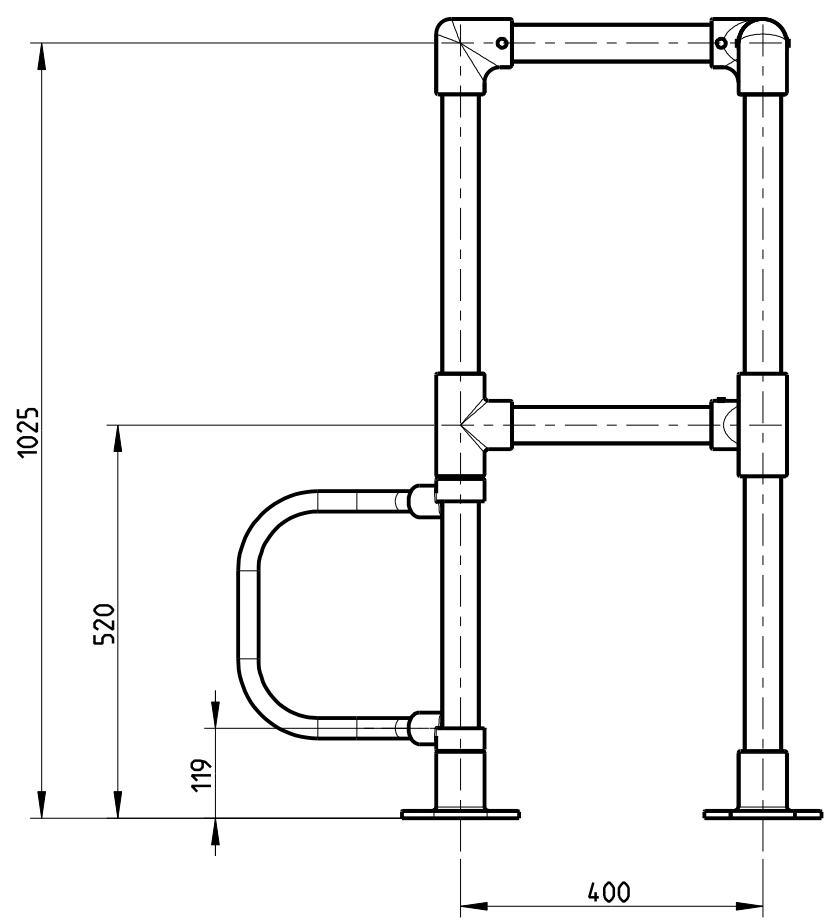

REP ITM	CODE SERCEL PART NUM.	DESIGNATION DESCRIPTION	REFERENCE / SPECIF / LA PART NUMBER / SPECIF.	QTE QTY
1	10011779	ANGLE SUPERIEUR / CORNER	SERCEL	1
2	10011788	ANGLE INTERMEDIAIRE / CORNER	SERCEL	1
3	10011790	SOCLE / FLOOR FLANGE	SERCEL	3
4	10011793	TE 90° / 90° TEE	SERCEL	2
5	10017480	ANGLE SUPERIEUR / CORNER	SERCEL	2
6	10017489	CROIX AJUSTABLE / CROSS	SERCEL	2
7	400260464	POTEAU / POST	SERCEL	3
8	400264044	LISSE / PIPE	SERCEL	2
9	400264054	LISSE / PIPE	SERCEL	2
10	400264064	POIGNEE DE GARDE CORPS / HANGER	SERCEL	1

F							
E							
D							
C							
B							
A	CREATION	SOUM D.	09-Apr-14	BUTTIN P.	09-Apr-14		
REV D/T	NATURE DE LA MODIFICATION TYPE OF MODIFICATION	DESSINE/VERIFIE DRAWN/VERIFIED	DATE	VISA	APPROUVE APPROVED	DATE	VISA
MATIERE/MATERIAL:				COULEUR/COLOR:		MASSE/WEIGHT: 0,033 T	
TRAITEMENT/TREATMENT:				VOLUME: m3		TOL.GEN./GEN.TOL.(Sauf specifi):	
TITRE/TITLE			LE PLAN ORIGINAL SIGNE EST AU PLANEX			ETAT DE SURFACE/MACHINE FINISH: SUIVANT INSTRUCTION: 9902000324	
N65 Neo			NUMERO DE PLAN / DRAWING REFERENCE			Echel: 0,100 Scale	
GARDE CORPS AV.DROIT / RIGHT FRONT GUARD RAIL			604141343			CLQ: /REF CL: ART	
			SERCEL ETABLISSEMENT DE SAINT GAUDENS CE PLAN EST LA PROPRIETE INALIENABLE DE BP 69 - 31802 SAINT-GAUDENS CEDEX (FRANCE) Tel:(33)(0)561899000 Fax:(33)(0)5 61899033 CODE OTAN : F2577			Folio: 1/1	
S 904 00 0233/00 Ce document est la propriété de SERCEL St-GAUDENS, toute reproduction et diffusion sont interdites sans son autorisation							

D C B A DRW 604141343 Version AA

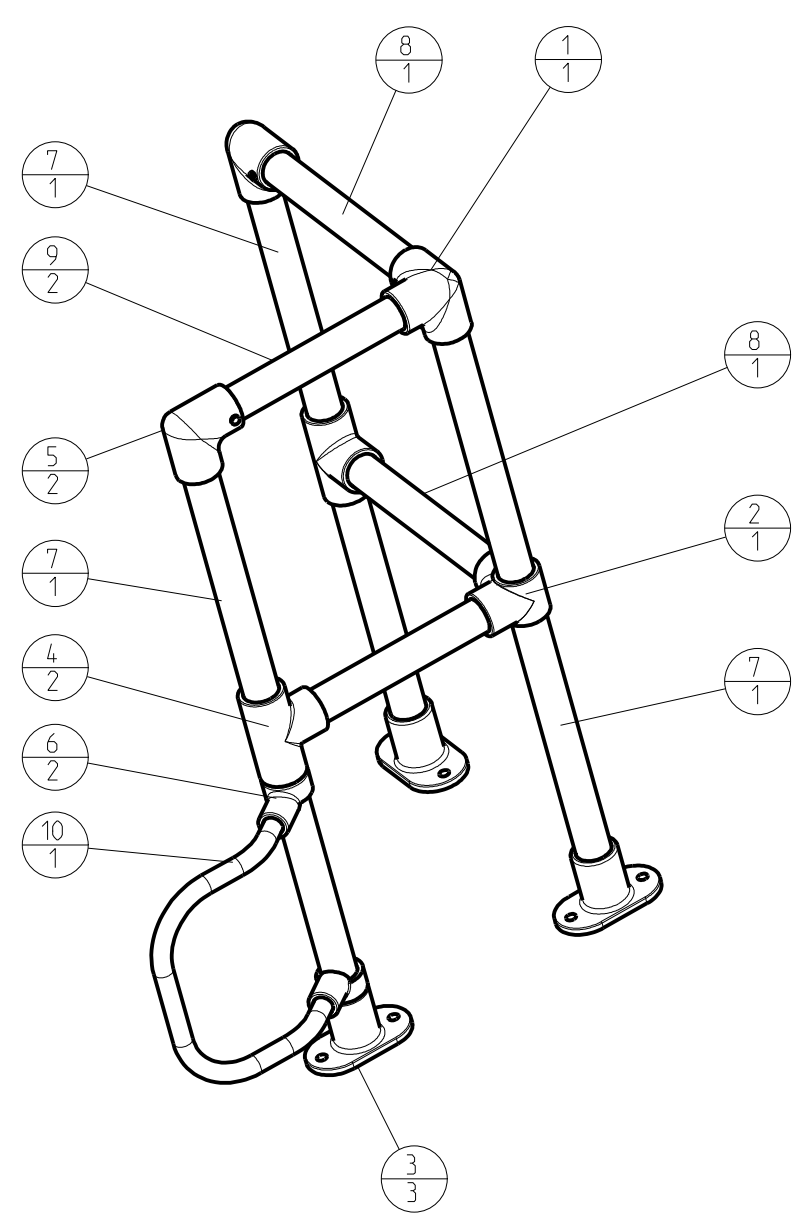
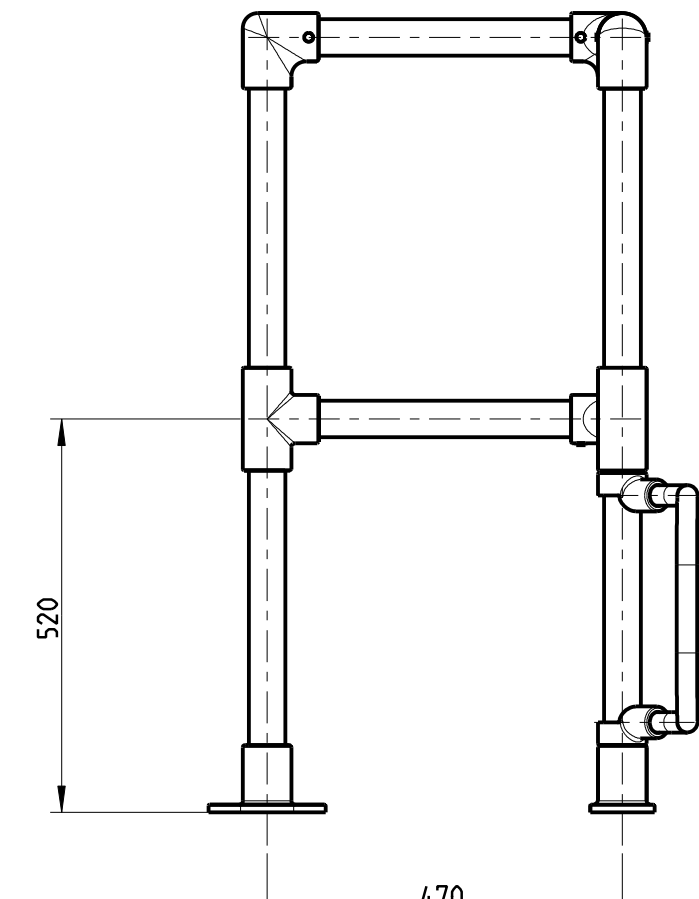
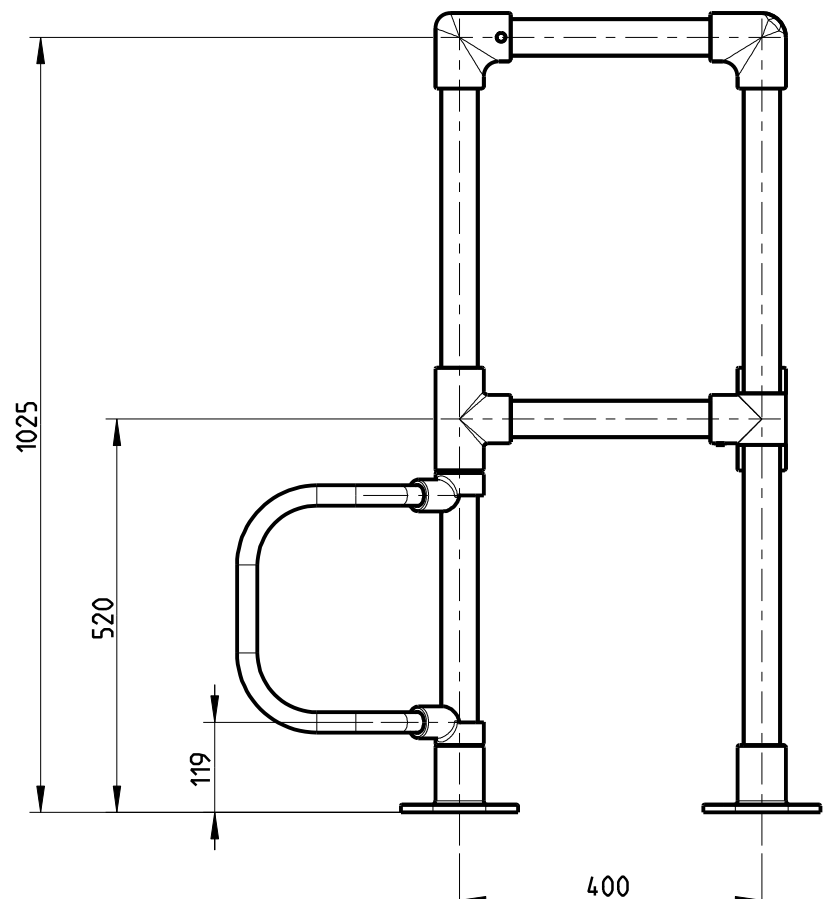

REP ITM	CODE SERCEL PART NUM.	DESIGNATION DESCRIPTION	REFERENCE / SPECIF / LA PART NUMBER / SPECIF.	QTE QTY
1	10011779	ANGLE SUPERIEUR / CORNER	SERCEL	1
2	10011788	ANGLE INTERMEDIAIRE / CORNER	SERCEL	1
3	10011790	SOCLE / FLOOR FLANGE	SERCEL	3
4	10011793	TE 90° / 90° TEE	SERCEL	2
5	10017480	ANGLE SUPERIEUR / CORNER	SERCEL	2
6	10017489	CROIX AJUSTABLE / CROSS	SERCEL	2
7	400260464	POTEAU / POST	SERCEL	3
8	400264044	LISSE / PIPE	SERCEL	2
9	400264054	LISSE / PIPE	SERCEL	2
10	400264064	POIGNEE DE GARDE CORPS / HANGER	SERCEL	1

F							
E							
D							
C							
B							
A	CREATION	SOUM D.	09-Apr-14	BUTTIN P.	09-Apr-14		
REV D/T	NATURE DE LA MODIFICATION TYPE OF MODIFICATION	DESSINE/VERIFIE DRAWN/VERIFIED	DATE	VISA	APPOUVE APPROVED	DATE	VISA
MATIERE/MATERIAL:				COULEUR/COLOR:		MASSE/WEIGHT: 0,033 T	
TRAITEMENT/TREATMENT:				VOLUME: m3		TOL.GEN./GEN.TOL.(Sauf specif):	
TITRE/TITLE				LE PLAN ORIGINAL SIGNE EST AU PLANEX			
N65 Neo				ETAT DE SURFACE/MACHINE FINISH: SUIVANT INSTRUCTION: 9902000324			
GARDE CORPS AV.GAUCHE / LEFT FRONT GUARD RAIL				NUMERO DE PLAN / DRAWING REFERENCE			
				604141333			
CE PLAN EST LA PROPRIETE INALIENABLE DE				SERCEL ETABLISSEMENT DE SAINT GAUDENS			
BP 69 - 31802 SAINT-GAUDENS CEDEX (FRANCE) Tel:(33)(0)561899000 Fax:(33)(0)5 61899033				Echel: 0,100 Scale CLO: /REF CL: ART			
CODE OTAN : F2577				Folio: 1/1			
S 904 00 0233/00 Ce document est la propriété de SERCEL St-GAUDENS, toute reproduction et diffusion sont interdites sans son autorisation							

D

C

B

A

REP ITM	CODE SERCEL PART NUM.	DESIGNATION DESCRIPTION	REFERENCE / SPECIF. / LA PART NUMBER / SPECIF.	QTE QTY
1	211111369	VIS H M12-40 8.8 ZB. / BOLT HEX ZINC-PLATED	SERCEL	4
2	216411120	ECROU M12, B. PLAST CL8 Z.B / NUT LOCK	SERCEL	4
3	217141120	RONDELLE M12,U,Z.B / PLAIN HEAVY DUTY WASHER	SERCEL	8
4	400272393	PLATELAGE CHASSIS LIFT D. / RIGHT LIFT WALKWAY	SERCEL	1

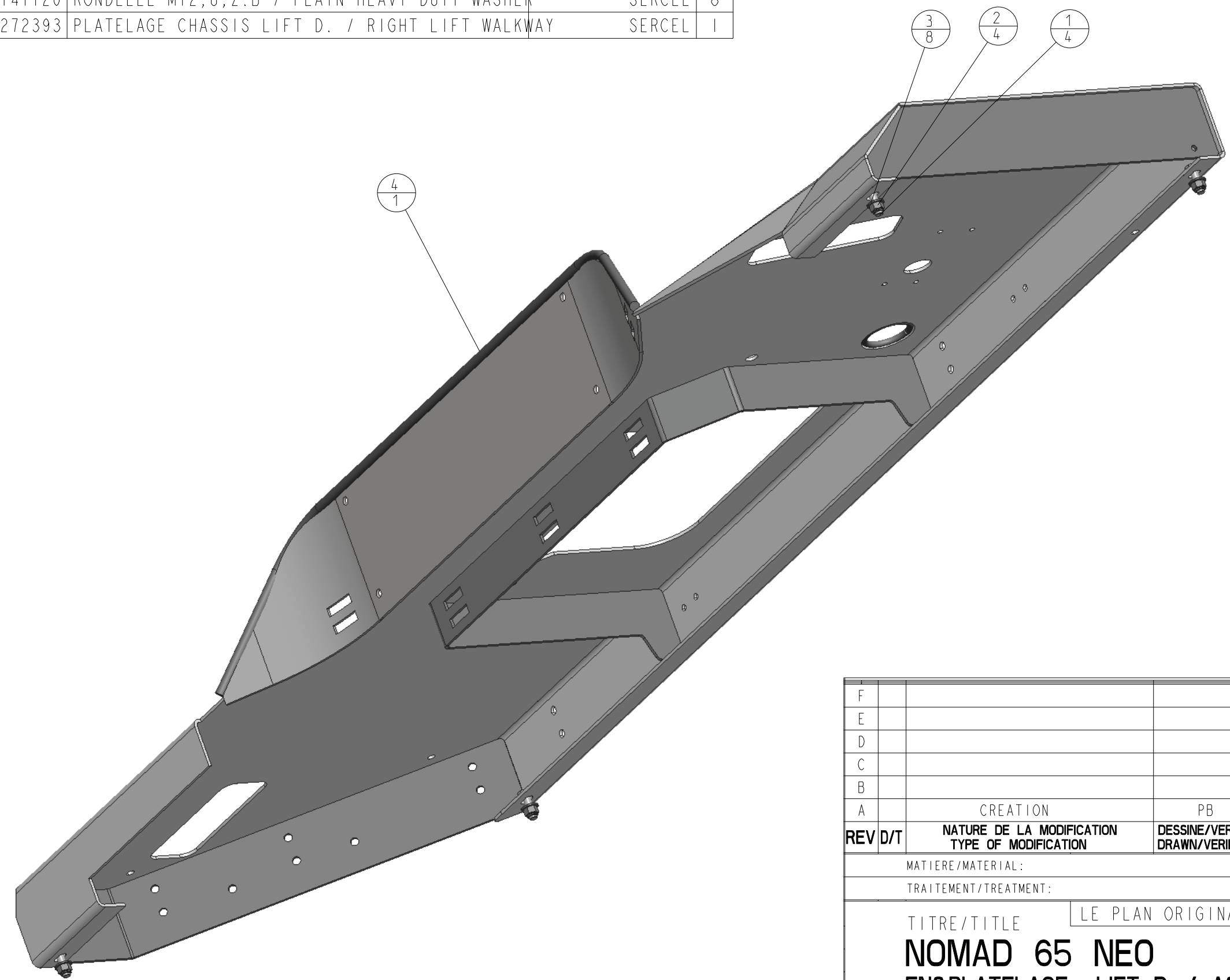

2

1

F									
E									
D									
C									
B									
A	CREATION	PB	Jul-21-16		BUTTIN P.	Jul-21-16			
REV	D/T	NATURE DE LA MODIFICATION TYPE OF MODIFICATION	DESSINE/VERIFIE DRAWN/VERIFIED	DATE	VISA	APPOUVE APPROVED	DATE	VISA	
MATIERE/MATERIAL:				COULEUR/COLOR:		MASSE/WEIGHT: 0,089 T			
TRAITEMENT/TREATMENT:				VOLUME: m3					
TITRE/TITLE						LE PLAN ORIGINAL SIGNE EST AU PLANEX			
NOMAD 65 NEO						ETAT DE SURFACE/MACHINE FINISH:			
ENS.PLATELAGE LIFT D. / ASSY.RIHGT LIFT WALKW.						SUIVANT INSTRUCTION: S902000324			
			CE PLAN EST LA PROPRIETE INALIENABLE DE			NUMERO DE PLAN / DRAWING REFERENCE			Echel: 0,150 Scale
SERCEL ETABLISSEMENT DE SAINT GAUDENS			BP 69 - 31802 SAINT-GAUDENS CEDEX (FRANCE) Tel:(33)(0)561899000 Fax:(33)(0)5 61899033			604141473			CLQ: /REF CL: ART
CODE OTAN : F2577			S 904 00 0233/00 Ce document est la propriété de SERCEL St-GAUDENS, toute reproduction et diffusion sont interdites sans son autorisation						Folio: 1/1

D

C

B

A

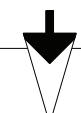

D

C

B

A

REP ITM	CODE SERCEL PART NUM.	DESIGNATION DESCRIPTION	REFERENCE / SPECIF. / LA PART NUMBER / SPECIF.	QTE QTY
1	211111369	VIS H MI2-40 8.8 ZB. / BOLT HEX ZINC-PLATED	SERCEL	4
2	216411120	ECROU MI2, B. PLAST CL8 Z.B / NUT LOCK	SERCEL	4
3	217141120	RONDELLE MI2,U,Z.B / PLAIN HEAVY DUTY WASHER	SERCEL	8
4	400272353	PLATELAGE CHASSIS LIFT G. / LEFT LIFT WALWAY	SERCEL	1

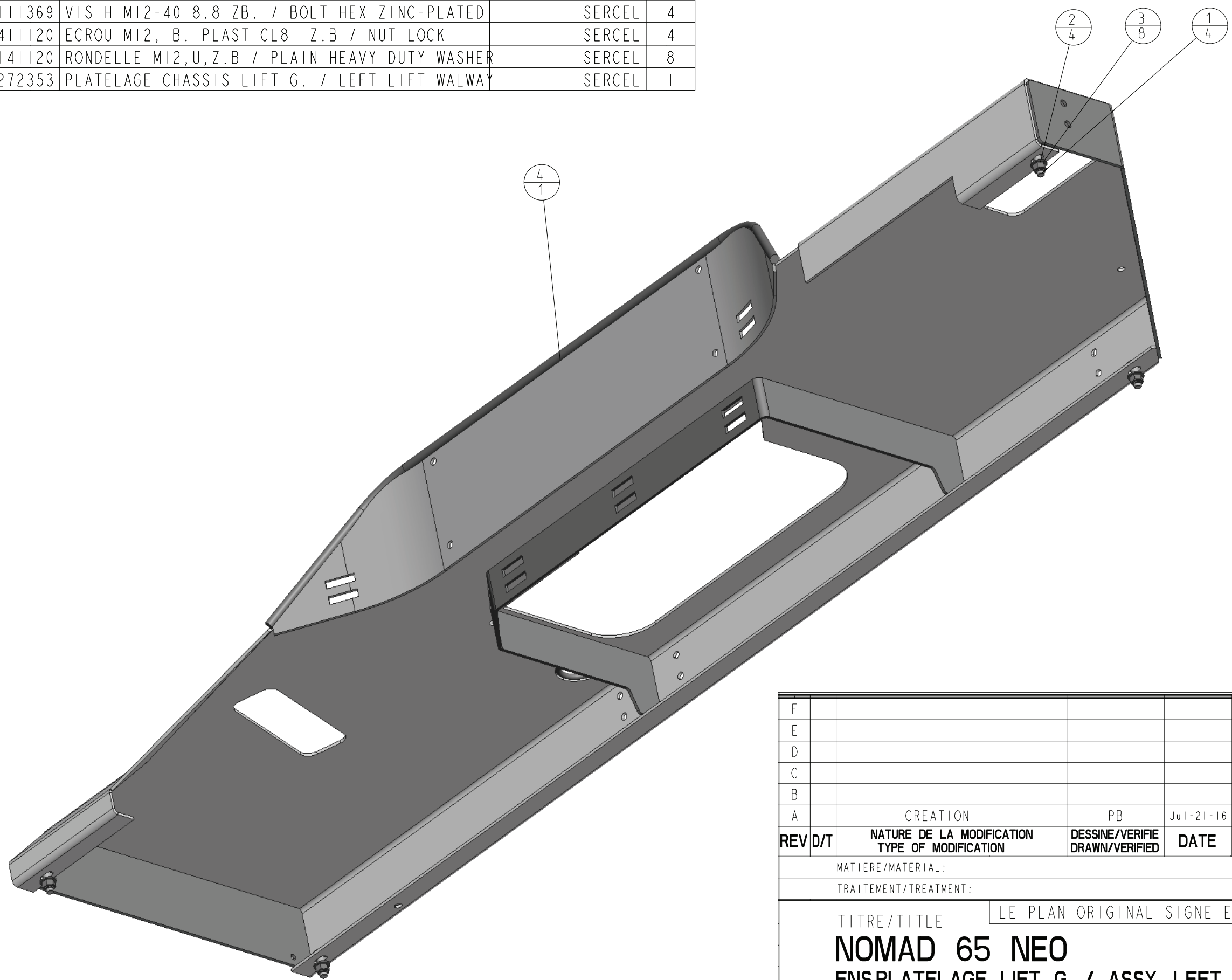

2

F									
E									
D									
C									
B									
A	CREATION	PB	Jul-21-16		BUTTIN P.	Jul-21-16			
REV D/T	NATURE DE LA MODIFICATION TYPE OF MODIFICATION	DESSINE/VERIFIE DRAWN/VERIFIED	DATE	VISA	APPOUVE APPROVED	DATE	VISA		
MATIERE/MATERIAL:				COULEUR/COLOR:		MASSE/WEIGHT: 0,090 T			
TRAITEMENT/TREATMENT:				VOLUME: m3					
TITRE/TITLE						LE PLAN ORIGINAL SIGNE EST AU PLAN EX			
NOMAD 65 NEO						ETAT DE SURFACE/MACHINE FINISH:			
ENS.PLATELAGE LIFT G. / ASSY. LEFT LIFT WALKW.						SUIVANT INSTRUCTION: S902000324			
		CE PLAN EST LA PROPRIETE INALIENABLE DE		NUMERO DE PLAN / DRAWING REFERENCE		Echel: 0,150			
SERCEL ETABLISSEMENT DE SAINT GAUDENS		BP 69 - 31802 SAINT-GAUDENS CEDEX (FRANCE) Tel:(33)(0)561899000 Fax:(33)(0)5 61899033		604141463		CLQ: /REF		CL: ART	
CODE OTAN : F2577						Folio: 1/1			
S 904 00 0233/00 Ce document est la propriété de SERCEL St-GAUDENS, toute reproduction et diffusion sont interdites sans son autorisation									

1

D

C

B

A

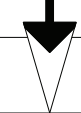

REP ITM	CODE TYPE DOC. NUMBER	CODE SERCEL PART NUM.	DESIGNATION DESCRIPTION	REFERENCE / SPECIF. / LA PART NUMBER / SPECIF.	QTE QTY	Long/ou volume
1		211111349	VIS H M 12-35 8.8 ZB.	SERCEL	6	
2		216411120	ECROU M12, B. PLAST CL8 Z.B	SERCEL	6	
3		217141120	RONDELLE M12,U,Z.B	SERCEL	12	
4	PF003	400182893	AILE AVANT DROITE	SERCEL	1	

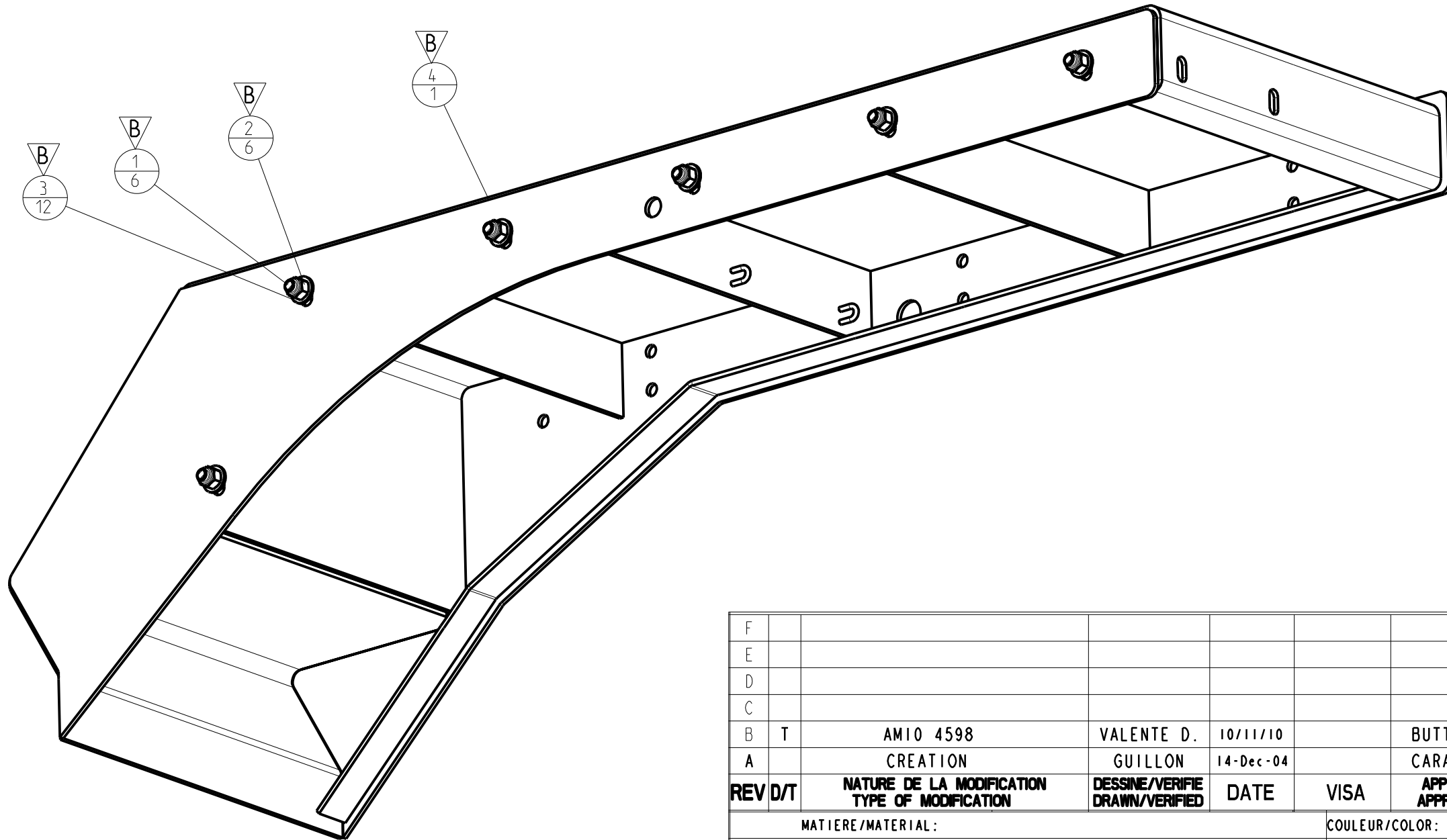

F									
E									
D									
C									
B	T	AM10 4598	VALENTE D.	10/11/10		BUTTIN P.	10/11/10		
A		CREATION	GUILLOIN	14-Dec-04		CARADEC	14-Dec-04		
REV D/T		NATURE DE LA MODIFICATION TYPE OF MODIFICATION	DESSINE/VERIFE DRAWN/VERIFIED	DATE	VISA	APPROUVE APPROVED	DATE	VISA	
MATIERE/MATERIAL:						COULEUR/COLOR:	MASSE/WEIGHT: 56,825 Kg		
TRAITEMENT/TREATMENT:						VOLUME: m3			
TITRE/TITLE						LE PLAN ORIGINAL SIGNE EST AU PLANEX		TOL.GEN./GEN.TOL.(Sauf specif):	
NOMAD 65								ETAT DE SURFACE/MACHINE FINISH:	
ENS.PLATELAGE RES.GO.D.								SUIVANT INSTRUCTION: S902000324	
			CE PLAN EST LA PROPRIETE INALIENABLE DE			NUMERO DE PLAN / DRAWING REFERENCE			Echel: 0,200
			SERCEL ETABLISSEMENT DE SAINT GAUDENS			PE003 604140423			Scale CLO: /REF CL: ART
CODE OTAN : F2577			BP 69 - 31802 SAINT-GAUDENS CEDEX (FRANCE) Tel:(33)(0)561899000 Fax:(33)(0)5 61899033						Folio: 1/1
S 904 00 0233/00 Ce document est la propriété de SERCEL ST-GAUDENS, toute reproduction et diffusion sont interdites sans son autorisation									

D

C

B

DRW 604140423 Version AB

A

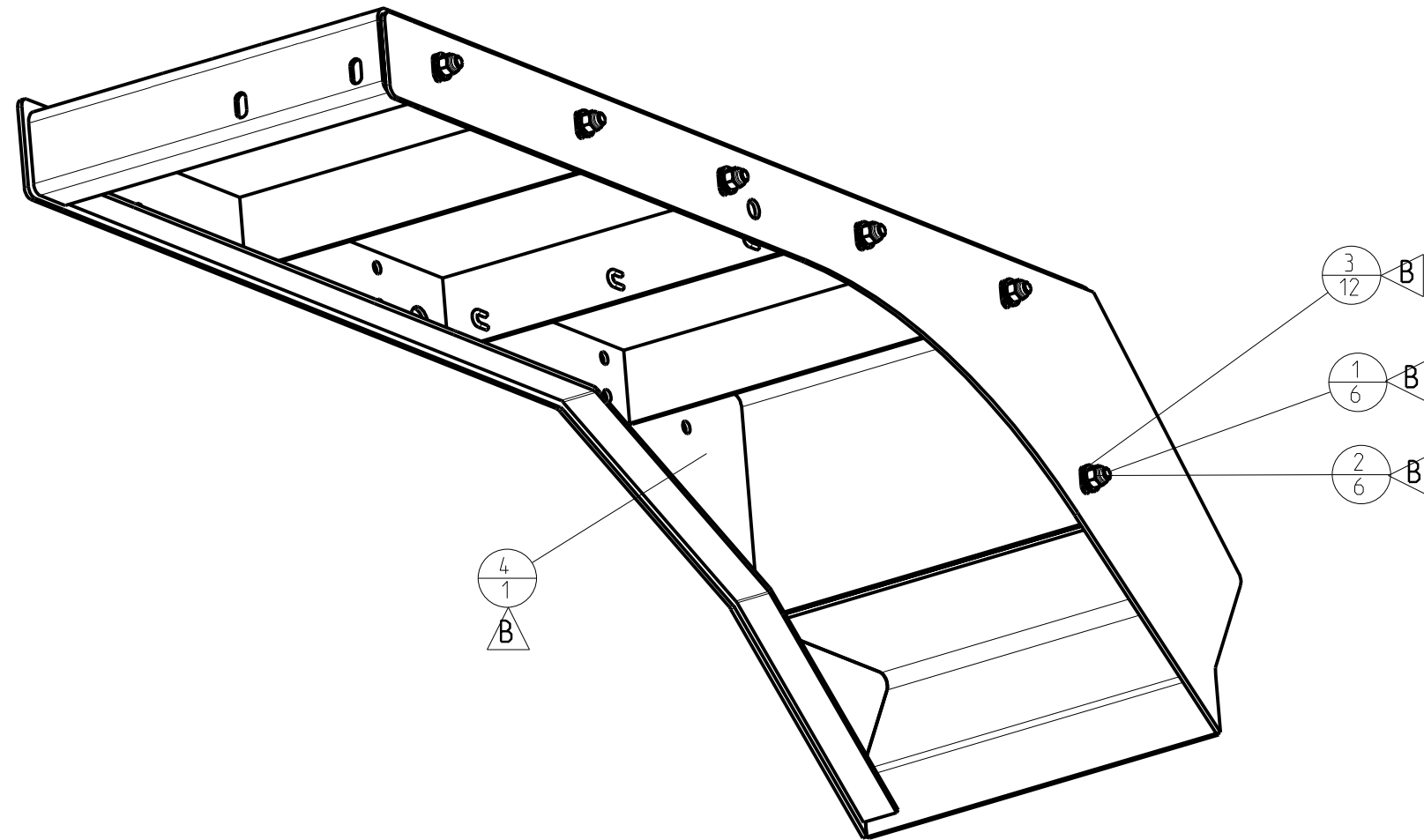

REP ITM	CODE TYPE DOC. TYPE NUMBER	CODE SERCEL PART NUM.	DESIGNATION DESCRIPTION	REFERENCE / SPECIF. / LA PART NUMBER / SPECIF.	QTE QTY	Long/ou volume
1		211111349	VIS H M 12-35 8.8 ZB.	SERCEL	6	
2		216411120	ECROU M12, B. PLAST CL8 Z.B	SERCEL	6	
3		217141120	RONDELLE M12,U,Z.B	SERCEL	12	
4	PF003	400182883	AILE AVANT GAUCHE	SERCEL	1	

F									
E									
D									
C									
B	T	AM10 4598	VALENTE D.	10/11/10		BUTTIN P.	10/11/10		
A		CREATION	GUILLOU	14-Dec-04		CARADEC	14-Dec-04		
REV D/T		NATURE DE LA MODIFICATION TYPE OF MODIFICATION	DESSINE/VERIFIE DRAWN/VERIFIED	DATE	VISA	APPROUVE APPROVED	DATE	VISA	
MATIERE/MATERIAL:						COULEUR/COLOR:		MASSE/WEIGHT: 56,825 Kg	
TRAITEMENT/TREATMENT:						VOLUME: m3			
TITRE/TITLE						LE PLAN ORIGINAL SIGNE EST AU PLANEX		TOL.GEN./GEN.TOL.(Sauf specif):	
NOMAD 65								ETAT DE SURFACE/MACHINE FINISH:	
ENS PLATELAGE RES.GO.G.								SUIVANT INSTRUCTION: S90200324	
						CE PLAN EST LA PROPRIETE INALIENABLE DE		NUMERO DE PLAN / DRAWING REFERENCE	
SERCEL ETABLISSEMENT DE SAINT GAUDENS						PE003 604140433		Echel: 0,150 Scale	
BP 69 - 31802 SAINT-GAUDENS CEDEX (FRANCE) Tel:(33)(0)561899000 Fax:(33)(0)5 61899033								CL : /REF CL : ART	
CODE OTAN : F2577								Folio: 1/1	
S 904 00 0233/00 Ce document est la propriété de SERCEL ST-GAUDENS, toute reproduction et diffusion sont interdites sans son autorisation									

D

C

B

DRW 604140433 Version AB

A

2

1

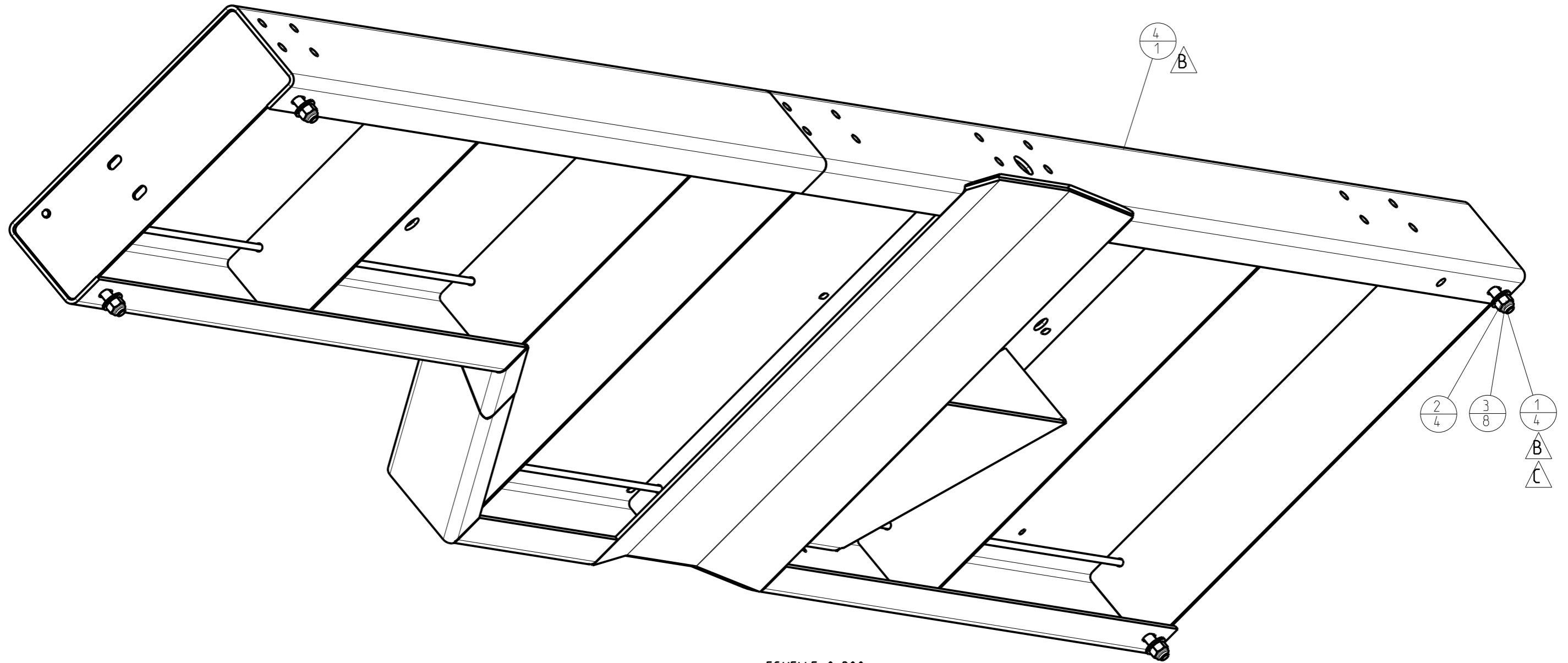

ECHELLE 0.200

REP ITM	CODE SERCEL PART NUM.	DESIGNATION DESCRIPTION	REFERENCE / SPECIF. / LA PART NUMBER / SPECIF.	QTE QTY
1	211111369	VIS H M12-40 8.8 ZB. / BOLT HEX	SERCEL	4
2	216411120	ECROU M12, B. PLAST CL8 Z.B / NUT LOCK	SERCEL	4
3	217141120	RONDELLE M12 , U , Z.B / WASHER FLAT	SERCEL	8
4	400185863	PLATELAGE MOTEUR D. / RIGHT REAR WALKWAY	SERCEL	1

F									
E									
D									
C	T	DM07 3617	SOUM D.	08/10/07		BUTTIN P.	08/10/07		
B	T	DM06 2459	SOUM D.	05/10/06		BUTTIN P.	05/10/06		
A		CREATION	GUILLON	17-Nov-04		BUTTIN P.	17-Nov-04		
REV D/T	NATURE DE LA MODIFICATION TYPE OF MODIFICATION	DESSINE/VERIFIE DRAWN/VERIFIED	DATE	VISA	APPROUVE APPROVED	DATE	VISA		
MATIERE/MATERIAL:				COULEUR/COLOR:		MASSE/WEIGHT: 0,156 T			
TRAITEMENT/TREATMENT:				VOLUME: m3					
TITRE/TITLE						LE PLAN ORIGINAL SIGNE EST AU PLANEX			
NOMAD 65						TOL.GEN./GEN.TOL.(Sauf specif):			
ENS.PLATELAGE CHASS.MOT.D. / ASSY.RIGHT REAR WALKW.						ETAT DE SURFACE/MACHINE FINISH: SUIVANT INSTRUCTION: S902000324			
CE PLAN EST LA PROPRIETE INALIENABLE DE			NUMERO DE PLAN / DRAWING REFERENCE			Echel: 0,050			
			SERCEL ETABLISSEMENT DE SAINT GAUDENS			CLQ: /REF CL : ART			
BP 69 - 31802 SAINT-GAUDENS CEDEX (FRANCE) Tel:(33)(0)561899000 Fax:(33)(0)5 61899033			PE003 604140463			Folio: 1/1			
S 904 00 0233/00 Ce document est la propriété de SERCEL St-GAUDENS, toute reproduction et diffusion sont interdites sans son autorisation									

REP ITM	CODE SERCEL PART NUM.	DESIGNATION DESCRIPTION	REFERENCE / SPECIF. / LA PART NUMBER / SPECIF.	QTE QTY
1	211111369	VIS H M12-40 8.8 ZB. / BOLT HEX	SERCEL	4
2	216411120	ECROU M12, B. PLAST CL8 Z.B / NUT LOCK	SERCEL	4
3	217141120	RONDELLE M12 , U , Z.B / WASHER FLAT	SERCEL	8
4	400185713	PLATELAGE MOTEUR G. / LEFT REAR WALKWAY	SERCEL	1

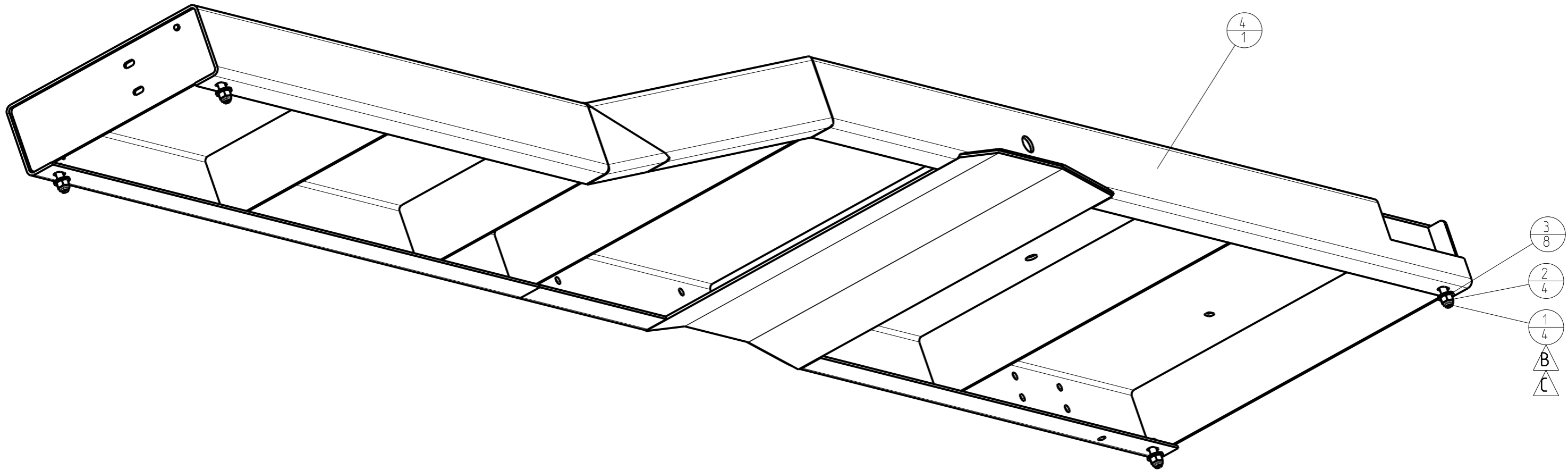

ECHELLE 0.150

F									
E									
D									
C	T	DM07 3617	SOUM D.	08/10/07		BUTTIN P.	08/10/07		
B	T	DM06 2459	SOUM D.	04/10/06		BUTTIN P.	04/10/06		
A		CREATION	GUILLON	17-Nov-04		BUTTIN P.	17-Nov-04		
REV D/T	NATURE DE LA MODIFICATION TYPE OF MODIFICATION	DESSINE/VERIFIE DRAWN/VERIFIED	DATE	VISA	APPROUVE APPROVED	DATE	VISA		
MATIERE/MATERIAL:				COULEUR/COLOR:		MASSE/WEIGHT: 0,152 T			
TRAITEMENT/TREATMENT:				VOLUME: m3					
TITRE/TITLE						LE PLAN ORIGINAL SIGNE EST AU PLANEX		TOL.GEN./GEN.TOL.(Sauf specif):	
NOMAD 65								ETAT DE SURFACE/MACHINE FINISH:	
ENS.PLATELAGE CHASS.MOT.G. / ASSY.LEFT REAR WALKW.								SUIVANT INSTRUCTION: S902000324	
				CE PLAN EST LA PROPRIETE INALIENABLE DE		NUMERO DE PLAN / DRAWING REFERENCE		Echel: 0,150	
				SERCEL ETABLISSEMENT DE SAINT GAUDENS		PE003 604140473		Scale CLO: /REF CL : 04 ART	
CODE OTAN : F2577				BP 69 - 31802 SAINT-GAUDENS CEDEX (FRANCE) Tel:(33)(0)561899000 Fax:(33)(0)5 61899033				Folio: 1/1	
S 904 00 0233/00 Ce document est la propriété de SERCEL St-GAUDENS, toute reproduction et diffusion sont interdites sans son autorisation									



SERCEL - ETABLISSEMENT DE SAINT-GAUDENS
BP.69 - 31802 SAINT-GAUDENS CEDEX
France

Tel.: (33) 05 61 89 90 00

Telex : 520 526 F

Fax : (33) 05 61 89 90 33

DATE : 15/03/2005

REV :

B

PART NUMBER : 604 160 104

DRW. NBR : 604 160 104

TITRE/TITLE : **ASSY, RERA LADDER
ENSEMBLE ECHELLE PARECHOC AR**

ITM	SERCEL P/N	DESCRIPTION	DESCRIPTION	QTY	UM
1	211111349	BOLT	VIS	2	UN
2	211111389	BOLT	VIS	2	UN
3	216411120	LOCK NUT	ECROU B. PLAST	4	UN
4	216411120	LOCK NUT	ECROU B. PLAST	8	UN
5	400161353	ROPE STEP	MARCHE PIED	1	UN
6	400174784	U / REAR LADDER	U_ECH. PARECHOC AR.	1	UN
7	400174824	U / REAR LADDER	U_ECH. PARECHOC AR.	1	UN

B

A

REP ITM	CODE TYPE DOC. TYPE NUMBER	CODE SERCEL PART NUM.	DESIGNATION DESCRIPTION	REFERENCE / SPECIF / LA PART NUMBER / SPECIF.	QTE QTY	Long/ou volume
1		211111349	VIS H M 12-35 8.8 ZB.	SERCEL	2	
2		211111389	VIS H M12-45 8.8 ZB.	SERCEL	2	
3		216411120	ECROU B. PLAST M12 CL8 Z.B	SERCEL	4	
4		217141120	RONDELLE M12 , U , Z.B	SERCEL	8	
5	PF003	400161353	MARCHE PIED	SERCEL	1	
6	PF004	400174784	U_ECH. PARECHOC AR.	SERCEL	1	
7	PF004	400174824	U_ECH. PARECHOC AR.	SERCEL	1	

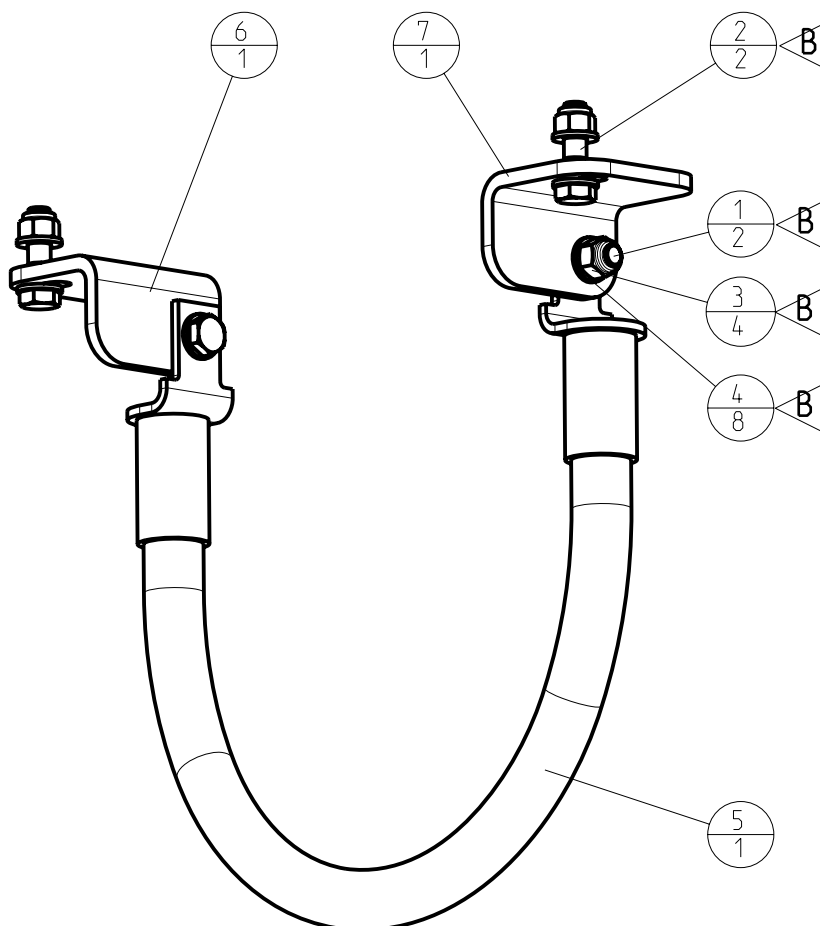

2

C									
B	T	DM04-0084	GUILLON	22-Fev-04		BUTTIN P.	22-Fev-04		
A		CREATION	GUILLON	08-Sep-03		BUTTIN P.	08-Sep-03		
REV	D/T	NATURE DE LA MODIFICATION TYPE OF MODIFICATION	DESSINE/VERIFIE DRAWN/VERIFIED	DATE	VISA	APPROUVE APPROVED	DATE	VISA	

1

MATIERE/MATERIAL:

TRAITEMENT/TREATMENT:

COULEUR/COLOR:

VOLUME: m3

MASSE/WEIGHT:
6,000 Kg

TITRE/TITLE

LE PLAN ORIGINAL SIGNE EST AU PLANEX

TOL.GEN./GEN.TOL.(Sauf specif):

NOMAD 65

ETAT DE SURFACE/MACHINE FINISH:

EGHELLE PARECHOC AR.

SUIVANT INSTRUCTION:

S902000324



CE PLAN EST LA PROPRIETE INALIENABLE DE

**SERCEL ETABLISSEMENT
DE SAINT GAUDENS**

NUMERO DE PLAN / DRAWING REFERENCE

PE004 604160104

Echel: 0,250

Scale

CLO:

/REF

CL: 04

ART

Folio: 1/1

CODE OTAN: F2577

BP 69 - 31802 SAINT-GAUDENS CEDEX (FRANCE)
Tel:(33)0561899000 Fax:(33)05 61899033

S 904 00 0233/00 Ce document est la propriété de SERCEL St-GAUDENS.

toute reproduction et diffusion sont interdites sans son autorisation

B

A

REP ITM	CODE SERCEL PART NUM.	DESIGNATION DESCRIPTION	REFERENCE / SPECIF / LA PART NUMBER / SPECIF.	QTE QTY
1	211311466	VIS CHC M6-65 8.8 ZB. / BOLT HEX HEAD SOC	SERCEL	4
2	216411060	ECROU M6, B. PLAST CL8 Z.B / NUT LOCK	SERCEL	4
3	217141060	RONDELLE M6,U Z.B / PLAIN HEAVY DUTY WASHER	SERCEL	4
4	227190039	COLLIER STAUFF 533.7AL / HOSE CLAMP	SERCEL	2
5	400246673	SUPPORT ANTENNE GPS / GPS ANTENA SUPPORT	SERCEL	1

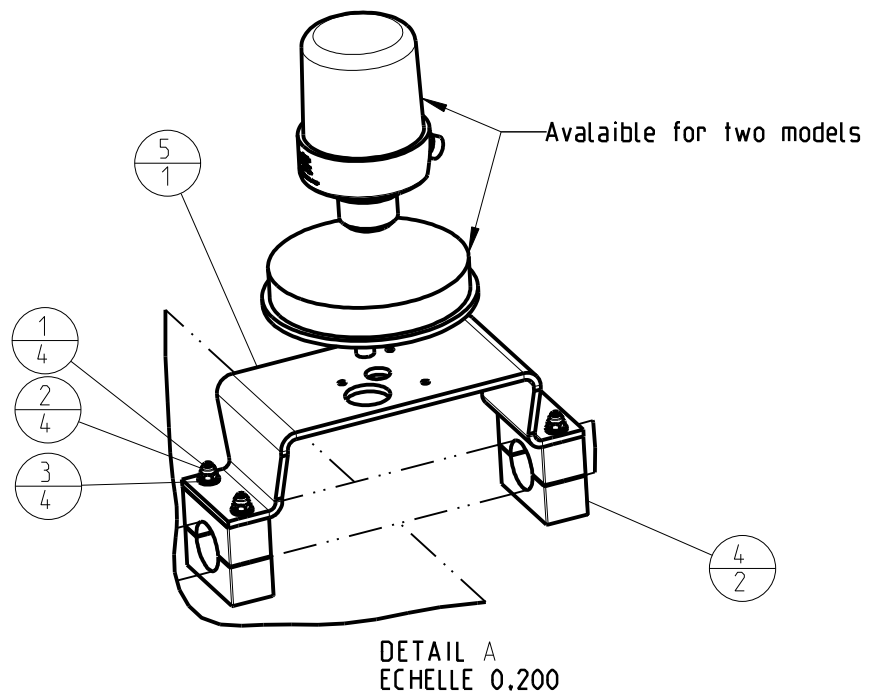
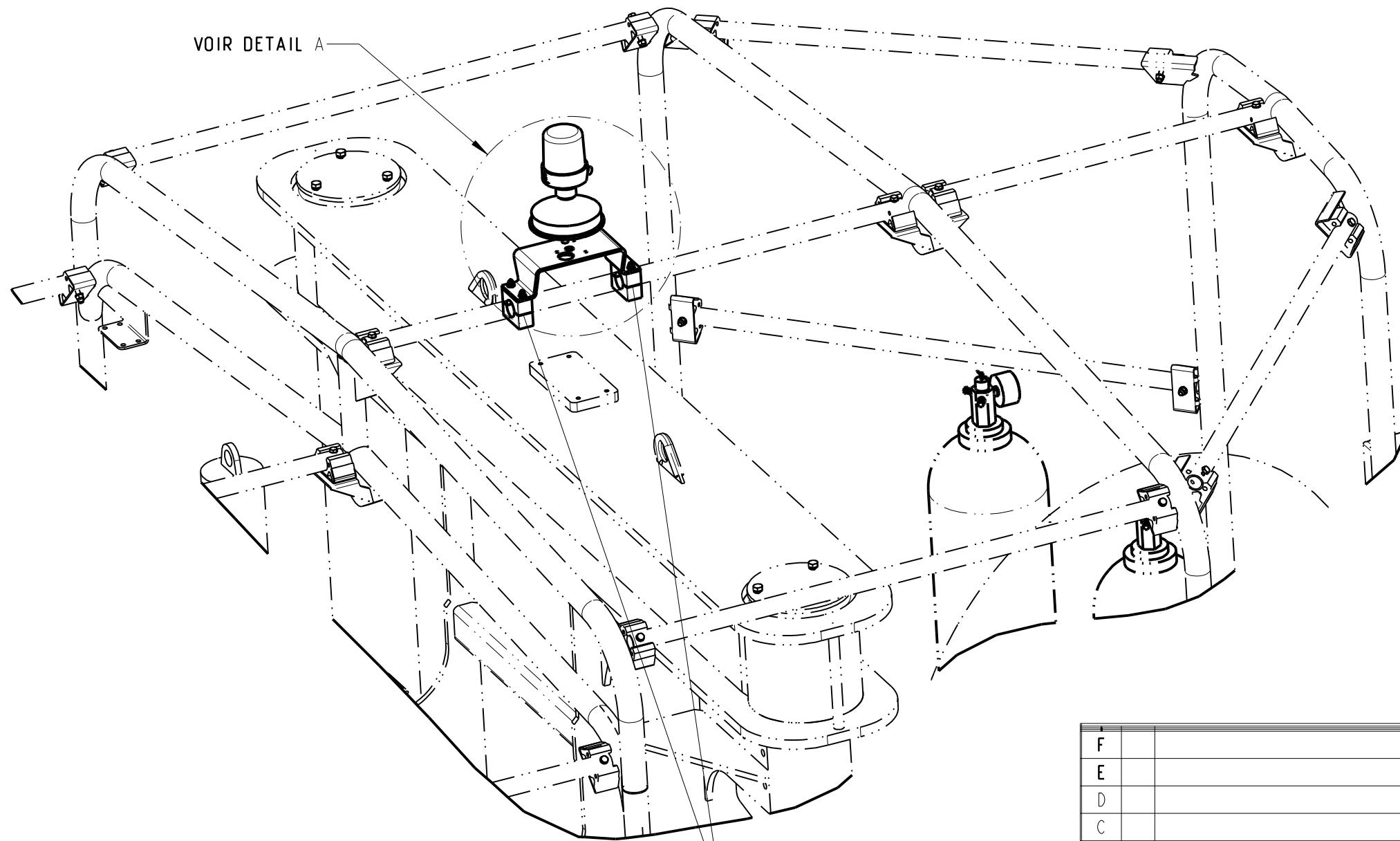

Percer la bache a la demande a la pose du support
Cut the tarpaulin when the antenna support is assembled

F								
E								
D								
C								
B					<i>Signé</i>			<i>Signé</i>
A	CREATION	SOUM D.	13-Sep-10	<i>D. Soum</i>	BUTTIN P.	13-Sep-10	<i>P. Buttin</i>	
REV D/T	NATURE DE LA MODIFICATION TYPE OF MODIFICATION	DESSINE/VERIFIE DRAWN/VERIFIED	DATE	VISA	APPROUVE APPROVED	DATE	VISA	
MATIERE/MATERIAL:				COULEUR/COLOR:		MASSE/WEIGHT: 496818,557 T		
TRAITEMENT/TREATMENT:				VOLUME: m3		TOL.GEN./GEN.TOL.(Sauf specifi):		
TITRE/TITLE N65 (-50 °) SUPPORT ANTENNE DGPS / DGPS ANTENA SUPPORT						LE PLAN ORIGINAL SIGNE EST AU PLANEX ETAT DE SURFACE/MACHINE FINISH: SUIVANT INSTRUCTION: S902000324		
SERCEL		CE PLAN EST LA PROPRIETE INALIENABLE DE SERCEL ETABLISSEMENT DE SAINT GAUDENS		NUMERO DE PLAN / DRAWING REFERENCE PE003 604791093		Echel: 0,100 Scale /CLO: /REF CL: ART Folio: 1/1		
CODE OTAN : F2577		BP 69 - 31802 SAINT-GAUDENS CEDEX (FRANCE) Tel:(33)(0)561899000 Fax:(33)(0)5 61899033						
S 904 00 0233/00 Ce document est la propriété de SERCEL St-GAUDENS, toute reproduction et diffusion sont interdites sans son autorisation								

D

C

B

DRW 604791093 Version AA

A

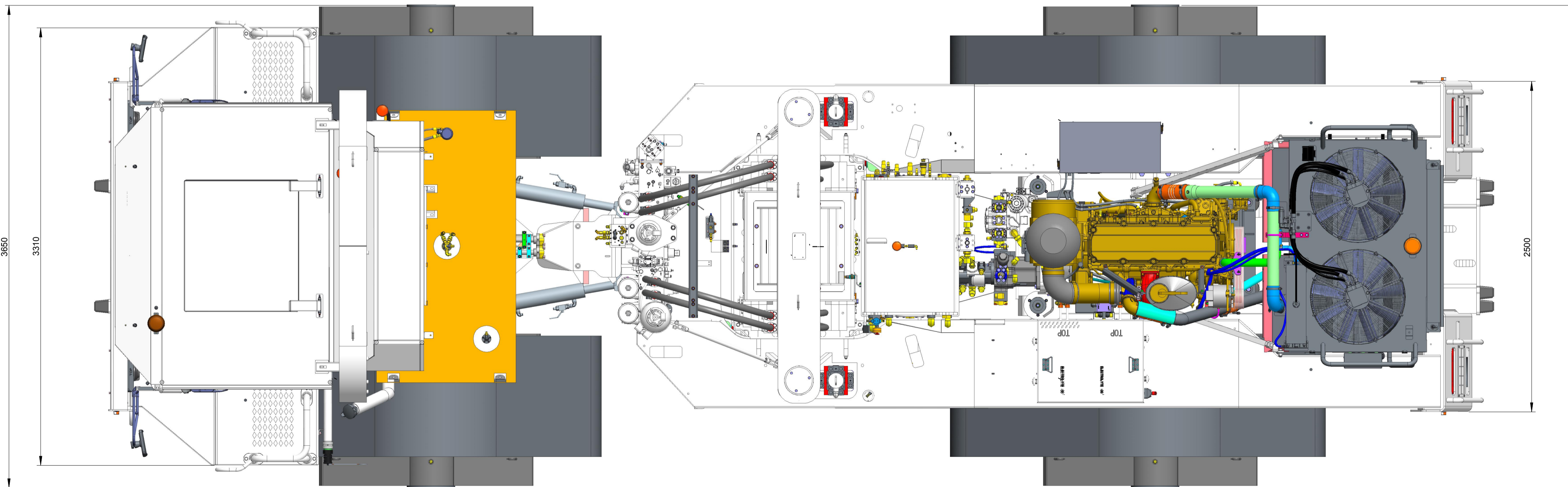
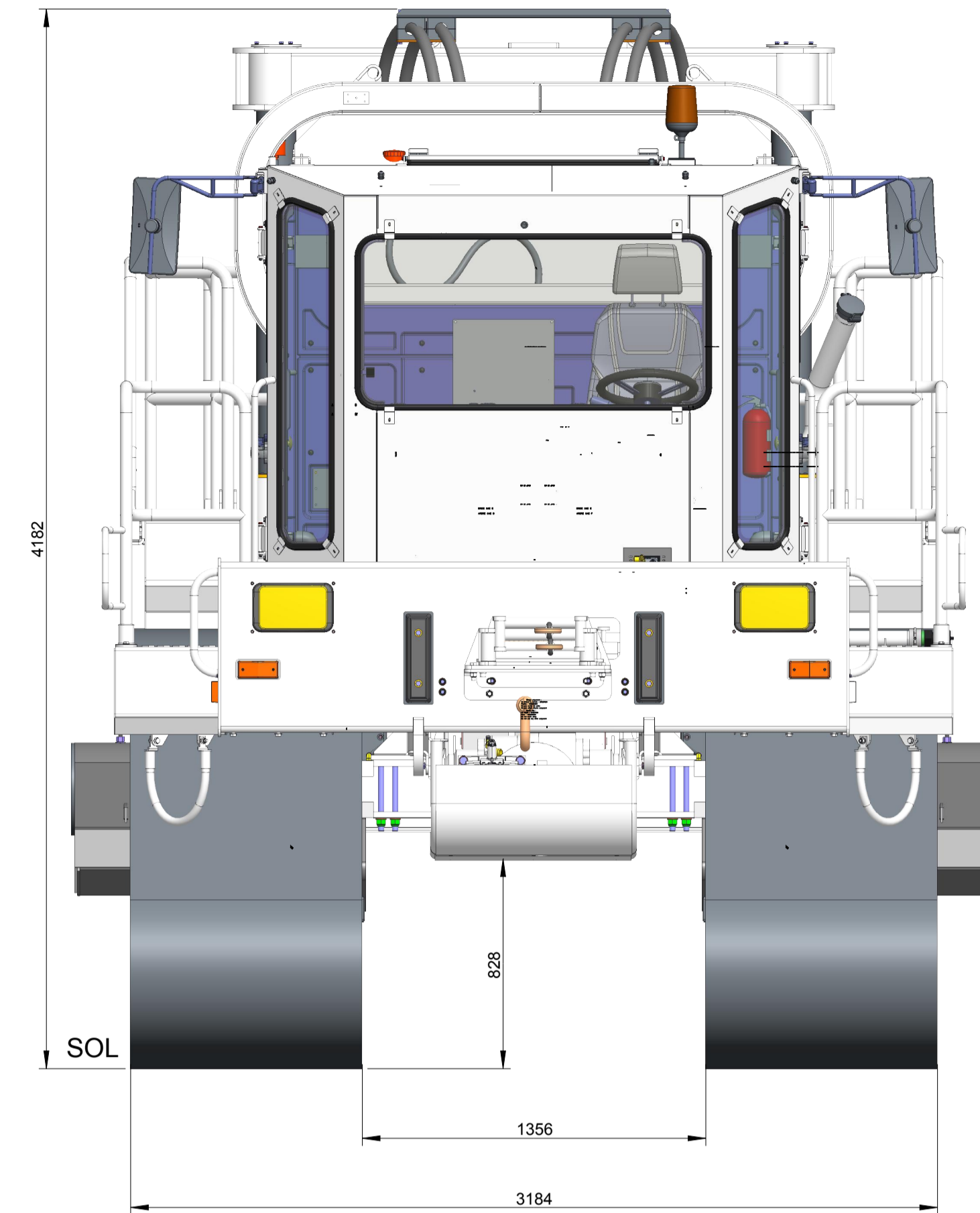
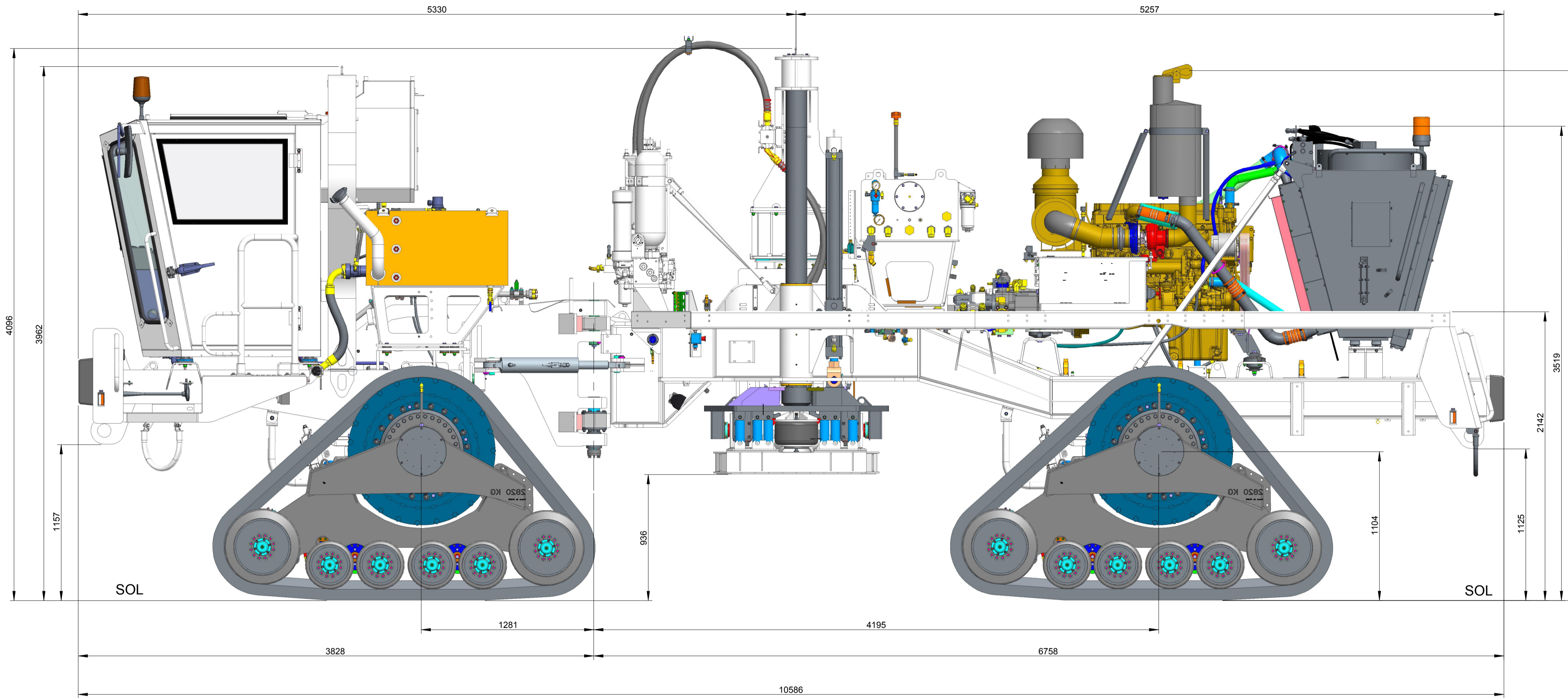

F										
E										
D										
C										
B										
A	CREATION	SOU M D.	18/07/16	BUT TIN P.	18/07/16					
REV/DIT	NATURE DE LA MODIFICATION TYPE OF MODIFICATION	DESSINE/VERIFIE DRAWN/VERIFIED	DATE	VISA	APPROUVE APPROVED	DATE	VISA			
	MATIERE/MATERIAL:		COULEUR/COLOR:		MASSE/WEIGHT:					
	TRAITEMENT/TREATMENT:		VOLUME: m3							
TITRE/TITLE										ETAT DE SURFACE/MACHINE FINISH:
N65 Neo										SUIVANT INSTRUCTION:
ENS_N65 NEO C13 CHENILLES / ASSY_N65 NEO C13 TRACKS										S90200324
CE PLAN EST LA PROPRIETE INALIENABLE DE										NUMERO DE PLAN / DRAWING REFERENCE
SERCEL ETABLISSEMENT										Echelle: 0,050
DE SAINT GAUDENS										CLQ:
BP 69 - 31802 SAINT GAUDENS CEDEX (FRANCE)										CL :
Tel:(33)0561899000 Fax:(33)05 61899033										NET
CODE OTAN : F2577										Folio: 1/1
S 904 00 023300 Ce document est la propriété de SERCEL St GAUDENS, toute reproduction et diffusion sont interdites sans son autorisation										

B

A

REP ITM	CODE TYPE DOC. TYPE NUMBER	CODE SERCEL PART NUM.	DESIGNATION DESCRIPTION	REFERENCE / SPECIF / LA PART NUMBER / SPECIF.	QTE QTY	Long/ou volume
1		211111349	VIS H M 12-35 8.8 ZB.	SERCEL	2	
2		211111389	VIS H M12-45 8.8 ZB.	SERCEL	4	
3		216411120	ECROU B. PLAST M12 CL8 Z.B	SERCEL	6	
4		217141120	RONDELLE M12 , U , Z.B	SERCEL	12	
5	PF003	400161353	MARCHE PIED	SERCEL	1	
6	PF003	400174764	RALLONGE ECH. PARECHOC AR.	SERCEL	1	
7	PF004	400174784	U_ECH. PARECHOC AR.	SERCEL	1	
8	PF004	400174824	U_ECH. PARECHOC AR.	SERCEL	1	

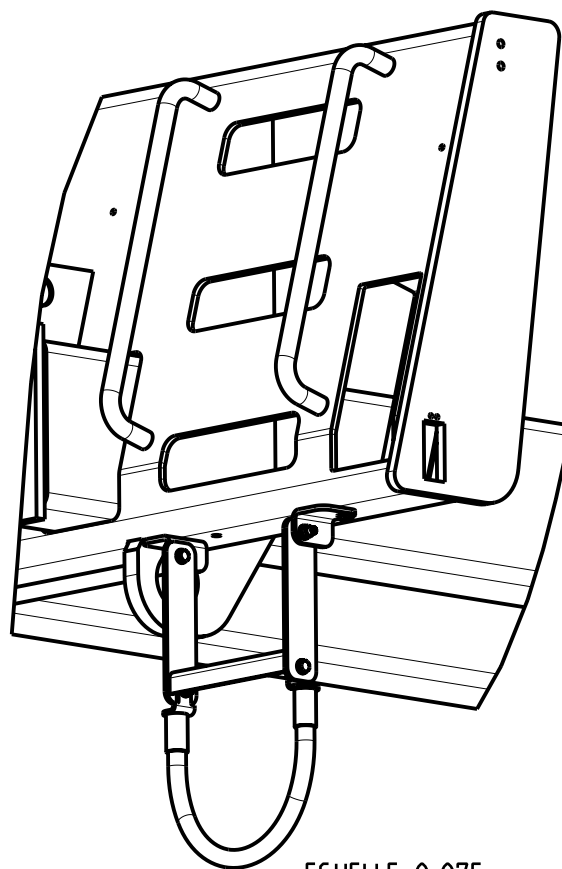
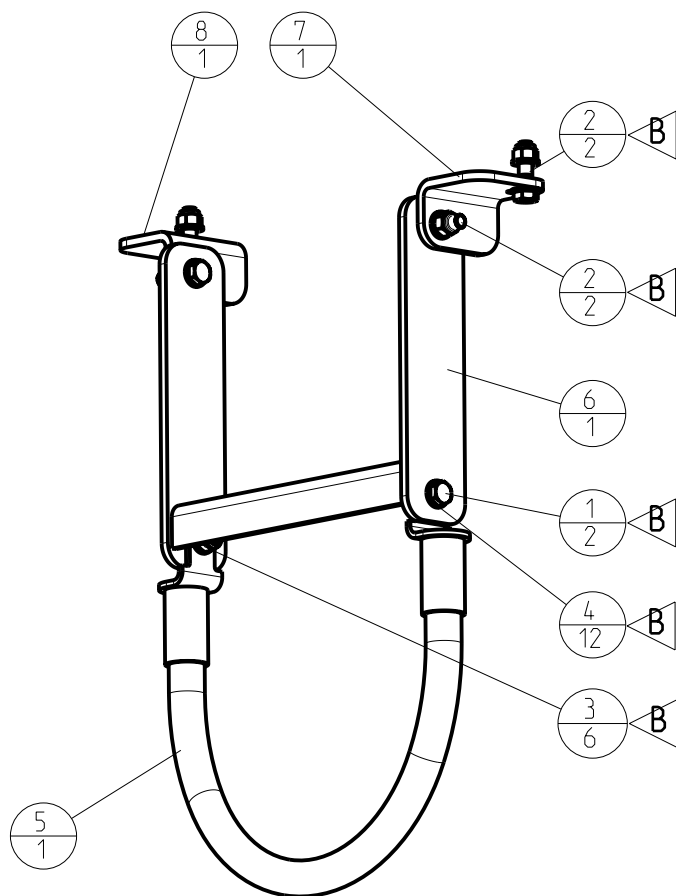

ECHELLE 0.075

C								
B	T	DM04 0084	GUILON	22-Fev-04		BUTTIN P.	22-Fev-04	
A		CREATION	GUILON	08-Sep-03		BUTTIN P.	08-Sep-03	
REV D/T		NATURE DE LA MODIFICATION TYPE OF MODIFICATION	DESSINE/VERIFIE DRAWN/VERIFIED	DATE	VISA	APPROUVE APPROVED	DATE	VISA

MATIERE/MATERIAL:

COULEUR/COLOR:

MASSE/WEIGHT:
0,000 Kg

TRAITEMENT/TREATMENT:

VOLUME: m3

TITRE/TITLE

LE PLAN ORIGINAL SIGNE EST AU PLANEX

TOL.GEN./GEN.TOL.(Sauf specifi):

NOMAD 65 TRACK

ETAT DE SURFACE/MACHINE FINISH:

RALLONGE ECH. PARECHOC AR.SUIVANT INSTRUCTION:
5902000324

CE PLAN EST LA PROPRIETE INALIENABLE DE
**SERCEL ETABLISSEMENT
 DE SAINT GAUDENS**

NUMERO DE PLAN / DRAWING REFERENCE
PE004604160094

Echel: **0,150**
 Scale
 CLO:
 /REF
 CL : **06**
 ART
 Folio: **1/1**

CODE OTAN : F2577

BP 69 - 31802 SAINT-GAUDENS CEDEX (FRANCE)
 Tel:(33)(0)561899000 Fax:(33)(0)5 61899033

S 904 00 0233/00 Ce document est la propriété de SERCEL ST-GAUDENS, toute reproduction et diffusion sont interdites sans son autorisation

B

DRW 604160094 Version AB

A

VALIDE-RELEASED

REP ITEM	CODE TYPE TYPE NUMBER	CODE SERCEL PART NUM.	DESIGNATION DESCRIPTION	REFERENCE / SPECIF. / LA PART NUMBER / SPECIF.	QTE QTY	VERSION
1		10016099	RONDELLE L24,U,Z.Bleu	SERCEL	8	
2		216421240	ECROU M24, B. PLAST CL10	SERCEL	8	

configuration	cadence	sans treuil			avec treuil		
		lest	tirant court	tirant long	lest	tirant court	tirant long
		400184653	400184674	400276174	400184653	400184674	400276174
N65 C13	< 161	0	0	0	14	4	0
N65 C15	< 161	0	0	0	4	4	0
N65 C13	>= 161	12	4	0	26	0	4
N65 C15	>= 161	12	4	0	16	4	0

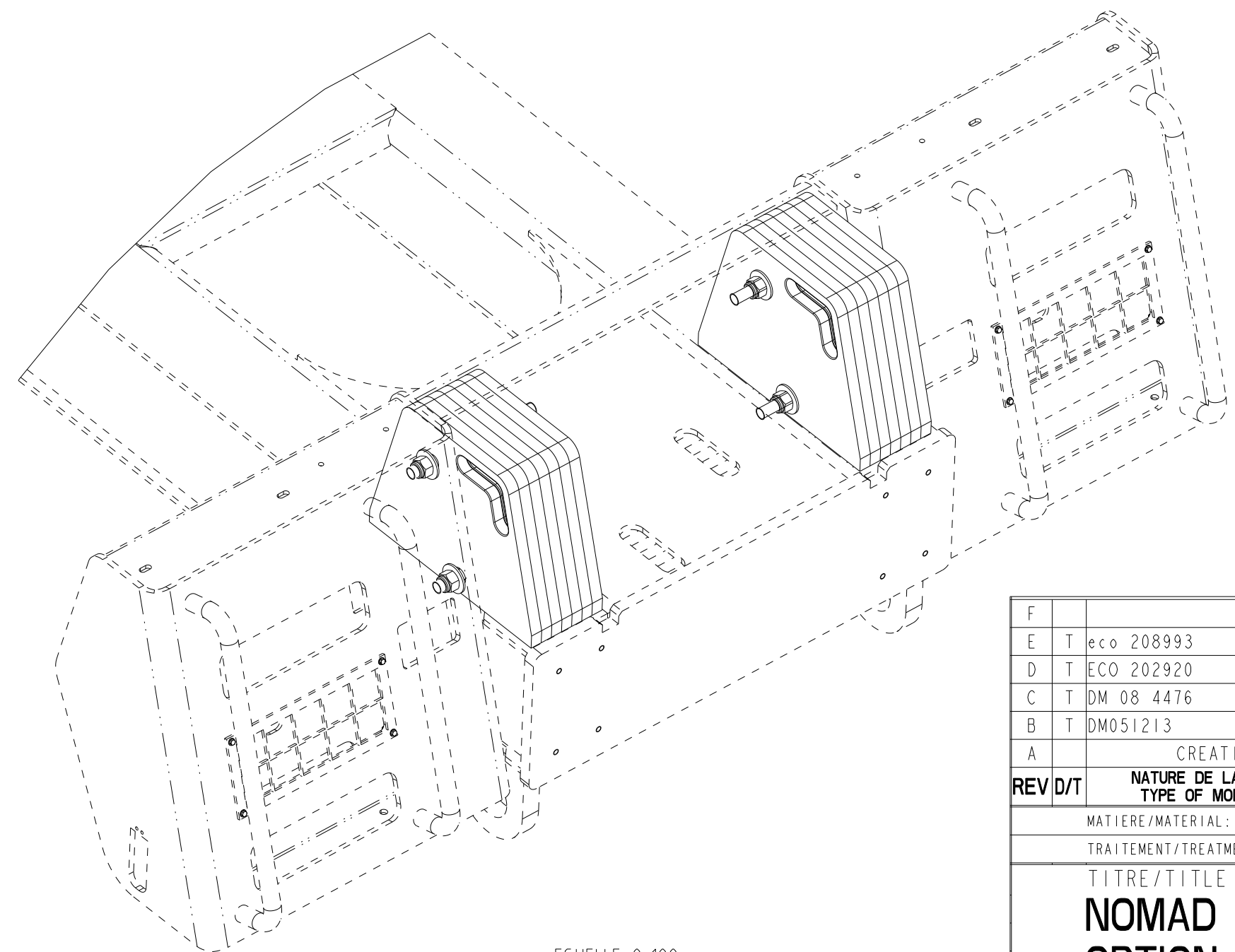

ECHELLE 0,100

F									
E	T	eco 208993	gcr	18/06/18	gcr	18/06/18			
D	T	ECO 202920	SOUM D.	17/02/14	BUTTIN P.	17/02/14			
C	T	DM 08 4476	LMASLANK	25-06-08	P.BUTTIN	25-06-08			
B	T	DM051213	CARADEC	13-06-05	CARADEC	13-06-05			
A		CREATION	GUILLOIN	01-Dec-04	CARADEC	01-Dec-04			
REV	D/T	NATURE DE LA MODIFICATION TYPE OF MODIFICATION	DESSINE/VERIFIE DRAWN/VERIFIED	DATE	VISA	APPOUVE APPROVED	DATE	VISA	
MATIERE/MATERIAL:						COULEUR/COLOR:		MASSE/WEIGHT: 1698,236 Kg	
TRAITEMENT/TREATMENT:						VOLUME: m3			
TITRE/TITLE				LE PLAN ORIGINAL SIGNE EST AU PLANEX			TOL.GEN./GEN.TOL.(Sauf specif):		
NOMAD 65							ETAT DE SURFACE/MACHINE FINISH:		
OPTION LEST							SUIVANT INSTRUCTION: S902000324		
				CE PLAN EST LA PROPRIETE INALIENABLE DE			NUMERO DE PLAN / DRAWING REFERENCE		
SERCEL ETABLISSEMENT DE SAINT GAUDENS							PE003 604190403		
BP 69 - 31802 SAINT-GAUDENS CEDEX (FRANCE) Tel:(33)(0)561899000 Fax:(33)(0)5 61899033 CODE OTAN : F2577							Echel: 0,023 Scale CLQ: Z /REF CL : 04 ART Folio: 1/1		
S 904 00 0233/00 Ce document est la propriété de SERCEL St-GAUDENS, toute reproduction et diffusion sont interdites sans son autorisation									